

---

## VSM

---

Chapter 1	■ Safety .....	page 3
Chapter 2	■ Introduction .....	page 5
Chapter 3	■ Product concept .....	page 7
Chapter 4	■ Selection of VSM unit.....	page 9
Chapter 5	■ Technical data .....	page 13
Chapter 6	■ Mechanical specifications .....	page 17
Chapter 7	■ Local control .....	page 25
Chapter 8	■ Parameters.....	page 35
Chapter 9	■ Serial communication .....	page 71
Chapter 10	■ Special conditions .....	page 81
Chapter 11	■ List of warnings and alarms .....	page 91
Chapter 12	■ List of parameters .....	page 97
Chapter 13	■ Index .....	page 101

When reading through this Design Guide, you will come across various symbols that require special attention.

The symbols used are the following:



Indicates a general warning.



Indicates something to be noted by the reader.



Indicates a high-voltage warning.

**Chapter 1**

■ Safety ..... page 4



All operations must be carried out by appropriately trained personnel.

Use all lifting facilities provided e.g. both lifting points if fitted or single lifting point if fitted\*.

Vertical lifting - Prevent uncontrolled rotation.

Lift machine - Do not lift other equipment with motor lifting points only.

Before installation check for fan cover damage, shaft damage, foot/mounting damage, and loose fasteners. Check nameplate details.

Ensure level mounting surface, balanced mounting, not misaligned.

Gaskets, and/or sealants, and guards must be correctly fitted.

Correct belt tension.

Please observe derating rules, see "*Special conditions*".

\*Note: maximum hand lift is 20 kg below shoulder, but above ground level. Max. gross weights:

- Frame size 80: 15 kg
- Frame size 90 & 100: 30 kg
- Frame size 112: 45 kg
- Frame size 132: 80 kg



The voltage on the VSM unit is dangerous when it is connected

to mains. Incorrect installation of the VSM may lead to material damage or serious injury, or it may be fatal.

Consequently, the instructions in this manual as well as national and local rules and safety regulations must be complied with.

Touching the electrical parts may be fatal, even after the mains supply has been disconnected.

Wait at least 4 minutes.

- Installation must be fused and isolated correctly.

- Covers and cable entries must be fitted.



**NB!**

It is the user's or certified electrician's responsibility to ensure correct earthing and protection in accordance with applicable national and local requirements and standards.

■ **Safety regulations**

1. The VSM unit must be disconnected from mains if repair work is to be carried out. Check that the mains supply has been disconnected and that the necessary time has passed (4 minutes).
2. Correct protective earthing of the equipment must be established, the user must be protected against supply voltage, and the unit must be protected against overload in accordance with applicable national and local regulations. Use of RCD's (ELCB relays) is described in chapter 10.
3. The earth leakage currents are higher than 3.5 mA. This means that the VSM unit requires a fixed, permanent installation as well as reinforced protective earthing.

■ **Warning against unintended start**

1. The unit can be brought to a stop by means of digital commands, bus commands, or references, while the frequency converter is connected to mains. If personal safety considerations make it necessary to ensure that no unintended start occurs, these stop functions are not sufficient.
2. While parameters are being changed, the motor may start.
3. A unit that has been stopped may start if faults occur in the electronics of the VSM unit, or if a temporary overload or a fault in the mains supply ceases.

**Chapter 2**

■ Introduction ..... page 6

Specific technical publications on the Variable speed W motor:

**Design Guide:** Gives all required information for design purposes, and gives a good insight into the product concept, product range, technical data, control, programming, etc.

**Quick Setup:** Helps the users to quickly get their VSM unit installed and running.

The Quick Setup is always delivered with the unit.

If you have any questions concerning VSM unit, please call us. We have drive specialists all over the world ready to advise you on applications, programming, training and service.

**Chapter 3**

■ Product concept ..... page 8

■ **Integration of frequency converter and motor**

The Brook Crompton variable speed motor has a frequency converter onto the asynchronous motor gives infinite speed control in one unit.

The Variable speed W motor is a very compact alternative to the ordinary solution with a frequency converter and motor as separate units. The frequency converter is attached instead of the motor terminal box, and it is no higher than the standard terminal box, nor wider or longer than the motor (see chapter 6).

Installation is made extremely easy. Panel space is not a problem. There is no need for special details on wiring to meet the EMC directive, since motor cables

are not necessary. The only connections are mains and control connections.

Factory-set adaption between frequency converter and motor gives precise and energy efficient control in addition to eliminating pre-setting on site.

The VSM unit can be used in stand alone systems with traditional control signals, such as start/stop signals, speed references and closed loop process control or in multiple drive systems with control signals distributed by a field bus.

Combination of fieldbus and traditional control signals and closed loop PID control is possible.

Control structures

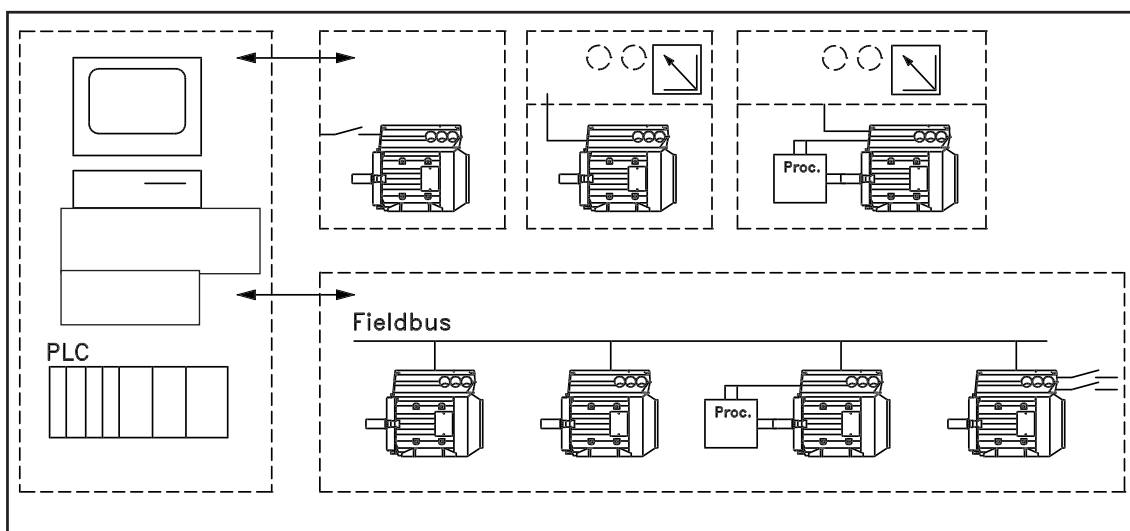

■ **Key diagram for VSM units**

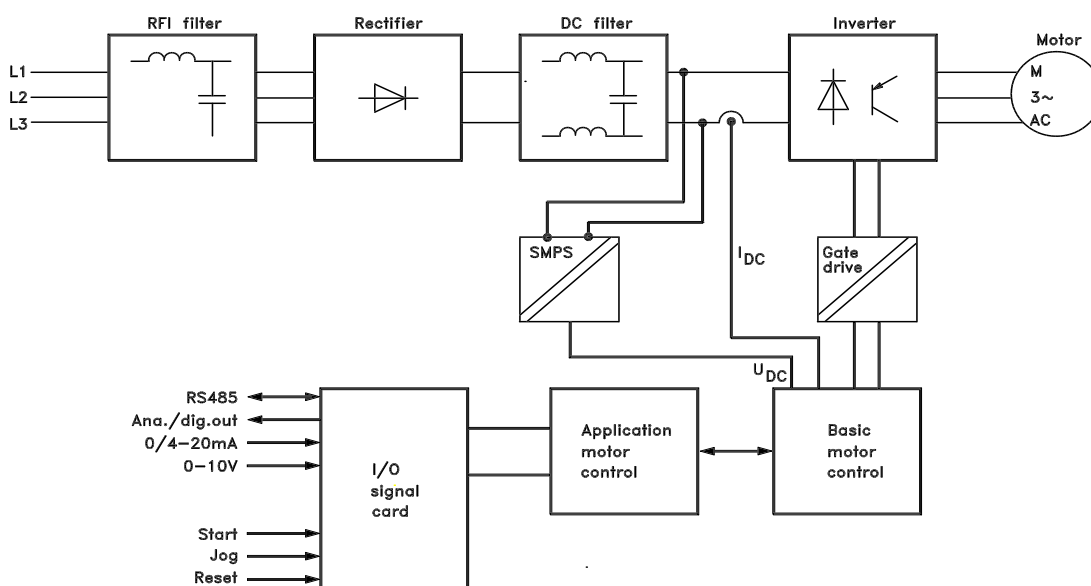

---

## VSM

---

### Chapter 4

- Product range ..... page 10
- Ordering ..... page 10

**■ Product range**

 Variable speed W 2 or 4 pole motors
 

---

Type	Motor output	Mains supply
<b>VSM 005</b>	0.55 kW	
<b>VSM 007</b>	0.75 kW	
<b>VSM 011</b>	1.1 kW	
<b>VSM 015</b>	1.5 kW	
<b>VSM 022</b>	2.2 kW	3 phase 380-480 V
<b>VSM 030</b>	3.0 kW	
<b>VSM 040</b>	4.0 kW	
<b>VSM 055</b>	5.5 kW	
<b>VSM 075</b>	7.5 kW	

Each type in the product range is available in different versions.

Inverter versions
*Drive control:*

- ST: Standard version
- SP: Version for PROFIBUS

*RFI filter:*

Inverter with integrated RFI filter, class A1 (industrial) or class B1 (domestic).

*Cooling:*

- TEFV: Motor cooled by a shaft mounted fan (IC 411)
- FV: Motor cooled by an independent fan (IC 416)

Mounting versions

- Foot mounting (B3)
- Flange mounting (B5)
- Face mounting (B14)
- Foot + flange mounting (B35)
- Foot + face mounting (B34)

See chapter 6.

*Inverter box position:* Top, right side or left side.

*Drainhole (+ position):* None, between feet, opposite feet, vertical drive end, vertical non-drive end, 90° right of feet, 90° left of feet.

*Brake kits:* No brake, brake with or without hand-release

**■ Ordering**

Take a copy of the ordering forms on page 12. Fill in and post or fax your order to the nearest branch office of the Brook Crompton sales organisation. On the basis of your order, the VSM unit is given a type code, which may look as follows:

VSM 030-P-T4-ST-S55-R1-100LT-4-1-B05-215-T-D1

This means that the VSM unit ordered is a VSM 030 for three-phase mains voltage of 380-480 V (T4) and for process applications (P). The inverter is a standard version for remote control (ST) in an IP55 enclosure (S55) with integrated RFI filter, class A1 (R1). The motor frame size is 100LT. The motor has 4 poles (4) and is cooled by a shaft mounted fan (1). The motor is for flange mounting (B05) and the flange size is 215 mm. The inverter box is mounted on the top of the motor (T) and the drainhole is placed between feet (D1).

If you wish to place your order by using the type code directly, please use the codes given in parenthesis on the left-hand side of the ordering forms. The code sequence in the type code is stated at the top of each part of the form (character number).

The ordering form for the basic unit must always be completed. When the type code is written, always state the characters of the basic string (1-30). Together with the order confirmation the customer receives an 8-figure code number to be used when reordering.

Software for serial communication

All VSM units have an RS 485 port as standard, which enables them to communicate e.g. with a PC. A programme entitled Brook Crompton Software is available for this purpose (see chapter 9).

Ordering numbers

VSM Software	175Z0953
--------------	----------

Incl Basic, Logging, Template, Guided tour modules in 6 languages (Danish, English, German, Italian, Spanish and French)

Accessories for the VSM unit

A Local Operation Pad (LOP) for local set point and start/stop is available for the VSM unit. The LOP is IP 66 enclosed. A Local Control Panel (LCP 2) which makes up a complete interface for operation, programming and monitoring of the VSM unit is also available.

Ordering numbers, accessories

Local Operation Pad (LOP)	175N0128
Local Control Panel (LCP 2)	175N0131
Remote mounting kit (LCP 2)	175N0160
Plug kit (LCP 2)	175N0161
Cable for plug kit (LCP 2)	175N0162
Cable (direct mounting) (LCP 2)	175N0165
Service plug kit (LCP 2)	175N0166

■ **Ordering info for Frames and Flanges**

Frame sizes and the corresponding flange sizes for different mounting versions

Type	Motor frame size		Mounting version	Flange size, standard (S) [mm]	Flange size, alternatives (A) [mm]	Flange size alternatives (B) [mm]
	4 pole	2 pole				
VSM 005	080MG	080MF	B5/B35	165	85/100/115/130	75/85/115/130/165
			B14/B34	100		
VSM 007	080MR	080MF	B5/B35	165	85/100/115/130	75/85/115/130/165
			B14/B34	100		
VSM 011	090LK	090SJ	B5/B35	165	100/115/130	215
			B14/B34	115		
VSM 015	090LT	090SJ	B5/B35	165	100/115/130	85/100/130/165
			B14/B34	115		
VSM 022	100LR	100LJ	B5/B35	215	165	85/100/115/215
			B14/B34	130		
VSM 030	100LT	100LM	B5/B35	215	165	85/100/115/215
			B14/B34	130		
VSM 040	112MT	112MS	B5/B35	215	115/130/165	85/100/115/215
			B14/B34	130		
VSM 055	132SJ	132SF	B5/B35	265	215	
			B14/B34	165		
VSM 075	132MT	132SJ	B5/B35	265	215	
			B14/B34	165		

Flange size according to IEC ref. FFxxx (Dimension M in chapter 6)

S: Available as standard shaft

A: Available as an alternative with specially elongated shaft to provide standard shaft for frame

B: Available as an alternative with standard shaft for frame, requiring no modification

■ **Ordering info for inverter box position and drain hole position.**

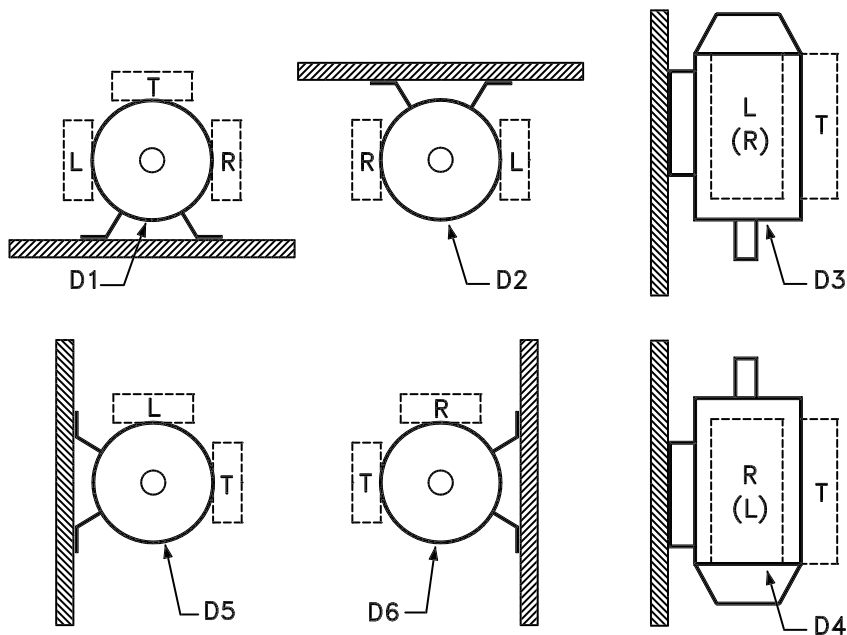

## VSM

Selection

### Ordering form VSM

VSM type (character nos. 1-6) **VSM**

Select the required VSM from the product range on the previous page and fill in the squares.

Application range (char. no. 7)

(P) **Process**

Mains voltage (char. nos. 8-9)

(T4) **3-phase 380-480 V AC**

Tick off as appropriate.

Inverter vs. (char. nos. 10-11)

(ST) **Standard**

(SP) **PROFIBUS**

Tick off as appropriate.

Enclosure (char. no. 12-14)

(S55) **IP55**

(S56) **IP56**

(S66) **IP66**

RFI filter (char. nos. 15-16)

(R1) **W/ integrated filter, class A1**

(R2) **W/integrated filter, class B1**

Tick off as appropriate.

Frame size (char. nos. 17-21)

Fill in the squares with the appropriate value from column 2 and 3 in the table on page 11.

Polarity (char. no. 22)

(4) **4 pole**

(2) **2 pole**

Tick off as appropriate.

Cooling (char. no. 23)

(1) (IC 411) **Shaft mounted fan**

(6) (IC 416) **Forced ventilation unit**

Tick off as appropriate.

### Ordering form VSM

Mounting vs. and flange size (char. nos. 24-29)

(B03) **B3 Foot**  **0 0 0**

(B05) **B5 Flange**  **flange size**

(B35) **Foot & flange**  **flange size**

(B14) **Face**  **flange size**

(B34) **Foot & face**  **flange size**

Tick off as appropriate and select flange size from the table on page 11.

Inverter box position (char. no. 30)

(T) **Top**

(R) **Right side**

(L) **Left side**

Tick off as appropriate.

Inverter box position is seen from drive end.

(See drawing on page 11).

Drain hole position (char. nos. 31-32)

(00) **None**

(D1) **Between feet**

(D2) **Opposite feet**

(D3) **Vertical drive end**

(D4) **Vertical non-drive end**

(D5) **90° right of feet**

(D6) **90° left of feet**

Tick off as appropriate.

(See drawing on page 11).

Other options (contact Brook crompton)

Number of VSM units ordered

### Ordered by:

Date: \_\_\_\_\_

---

## VSM

---

### Chapter 5

- VSM 005-075 for 3 phase, 380-480 V ..... page 14
- General technical data ..... page 14

■ VSM 005-075 for 3 phase, 380-480 V

Type	Motor output [kW]	Motor torque		Frame size [mm]	Weight [kg]	Input current				Power terminals [mm <sup>2</sup> ]	Gland sizes
		2 pole [Nm]	4 pole [Nm]			380 V		480 V			
						2 p [A]	4 p [A]	2 p [A]	4 p [A]		
VSM 005	0.55	1.8	3.5	80	11	-	1.4	-	1.1	4	3XPG16
VSM 007	0.75	2.4	4.8	80	13	1.3	1.7	1.1	1.4	4	3XPG16
VSM 011	1.1	3.5	7.0	90	17	2.2	2.5	1.8	2.0	4	3XPG16
VSM 015	1.5	4.8	9.6	90	20	2.8	3.3	2.3	2.6	4	3XPG16
VSM 022	2.2	7.0	14.0	100	26	4.1	4.7	3.3	3.7	4	3XPG16
VSM 030	3.0	9.5	19.1	100	28	5.3	6.4	4.2	5.1	4	3XPG16
VSM 040	4.0	12.6	25.4	112	37	7.0	7.9	5.6	6.4	4	1XPG21, 2XPG16
VSM 055	5.5	17.5	35.0	132	56	9.3	11.1	7.4	8.8	10	1XPG21, 2XPG16
VSM 075	7.5	24.0	48.0	132	61	13.0	15.3	10.2	11.9	10	1XPG21, 2XPG16

■ General technical data

Mains supply, TT, TN and IT\* (L1, L2, L3):

- Supply voltage 380-480 V units ..... 3 x 380/400/415/440/460/480 V ±10%
- Supply frequency ..... 50/60 Hz
- Max. imbalance of supply voltage ..... ±2% of rated supply voltage
- Power factor / cos φ ..... max. 0.9/1.0 at rated load
- No. of switching operations on supply input L1, L2, L3 ..... approx. 1 time/2 min
- Max prefuse ..... 25 A

See chapter 10, "Special conditions".

\*) Not valid for RFI class 1B units

Torque characteristics:

- Starting torque/overload torque ..... 160 % for 1 min
- Continuous torque ..... see page 84

Control card, digital/pulse inputs:

- Number of programmable digital inputs ..... 4
- Terminal nos. .... X101-2, -3, -4, -5
- Voltage level ..... 0-24 V DC (PNP positive logics)
- Voltage level, logic '0' ..... < 5 V DC
- Voltage level, logic '1' ..... > 10 V DC
- Maximum voltage on input ..... 28 V DC
- Input resistance, R<sub>i</sub> ..... approx. 2 kΩ
- Scanning time ..... 20 msec

Control card, pulse input:

- No. of programmable pulse inputs ..... 1
- Terminal nos. .... X101-3
- Max. frequency on terminal 3, open collector/push pull 24 V ..... 8 kHz/70 kHz
- Resolution ..... 10 bit
- Accuracy (0.1-1 kHz), terminal 3 ..... Max. error: 0.5% of full scale
- Accuracy (1-12 kHz), terminal 3 ..... Max. error: 0.1% of full scale

Control card, analogue inputs:

- No. of programmable analogue voltage inputs ..... 1
- Terminal nos. .... X101-2
- Voltage level ..... 0 - 10 V DC (scalable)
- Input resistance,  $R_i$  ..... approx. 10 k $\Omega$
- No. of programmable analogue current inputs ..... 1
- Terminal no. .... X101-1
- Current range ..... 0 - 20 mA (scalable)
- Input resistance,  $R_i$  ..... approx. 300  $\Omega$
- Resolution ..... 9 bit
- Accuracy on input ..... Max. error 1% of full scale
- Scanning time ..... 20 msec.

Control card, digital/pulse and analogue outputs:

- No. of programmable digital and analogue outputs ..... 1
- Terminal nos. .... X101-9
- Voltage level at digital output/load ..... 0 - 24 V DC/25 mA
- Current at analogue output ..... 0 - 20 mA
- Maximum load to frame (terminal 8) at analogue output .....  $R_{LOAD} \leq 500 \Omega$
- Accuracy of analogue output ..... Max. error: 1.5% of full scale
- Resolution on analogue output ..... 8 bit

Control card, RS 485 serial communication:

- Terminal nos. .... X100-1, -2

Control characteristics (frequency converter):

- Frequency range ..... 0 - 132 Hz
- Resolution on output frequency ..... 0.1 %
- System response time ..... Max. 40 msec.

Externals:

- Enclosure ..... IP 55 (IP56, IP66)
- Vibration test ..... (IEC 68 see page 85) 1 g
- Max. relative humidity ..... 93 % +2 %, -3 % (IEC 68-2-3) for storage/transport
- Ambient temperature ..... Max. 40°C (24-hour average max. 35°C)

*Derating for high ambient temperature, see chapter 10.*

- Min. ambient temperature in full operation ..... 0°C
- Min. ambient temperature at reduced performance ..... -10°C
- Temperature during storage/transport ..... -25 - +65/70°C
- Max. altitude above sea level ..... 1000 m

*Derating for air pressure, see chapter 10.*

- EMC standards applied, Emission ..... EN 50081-1/2, EN 61800-3, EN 55011, EN 55014  
Immunity ..... EN 50082-2, EN 61000-4-2, IEC 1000-4-3, EN 61000-4-4  
EN 61000-4-5, ENV 50140, ENV 50141
- Safety standards applied, ..... EN 60146, EN 50178, EN 60204

Protection:

- Thermal overload protection of motor and electronics.
- Monitoring of the intermediate circuit voltage ensures that the inverter cuts out if the intermediate circuit voltage gets too high or too low.
- If a mains phase is missing, the inverter will cut out when a load is placed on the motor.
- Overcurrent, and voltage transients protection.

Terminal arrangement (for installation see quick setup)

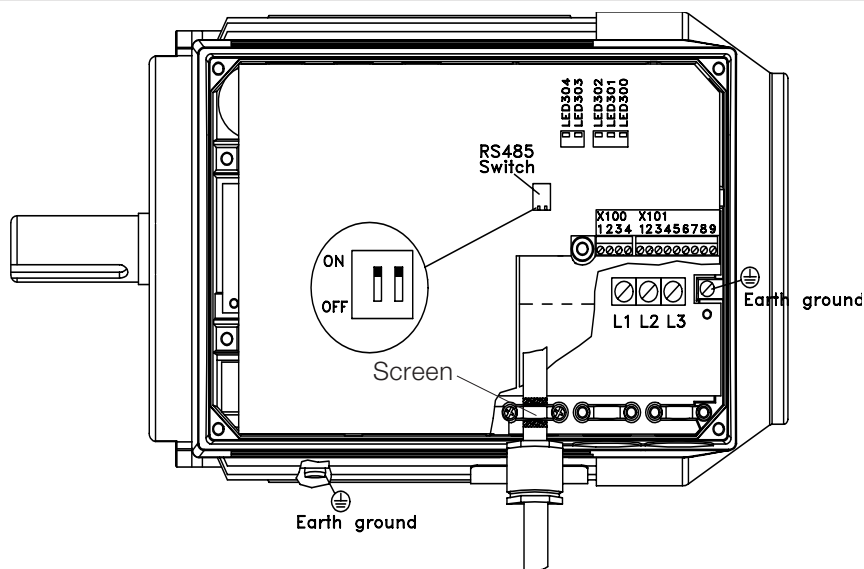

X101: Terminal block for analogue/digital control signals

Terminal No.	Function	Example
1	Analogue input (0-20 mA)	Feedback signal
2	Analogue (0-10 V)/digital input 2	Speed reference
3	Digital input (or pulse) 3	Reset
4	Digital input (or precise stop) 4	Start
5	Digital input (other) 5	Jog (fixed speed)
6	24 V DC supply for digital inputs (max. 150 mA)	
7	10 V DC supply for potentiometer (max. 15 mA)	
8	0 V for terminals 1-7 and 9	
9	Analogue (0-20 mA)/digital output	Fault indication

X100: Terminal block for data communication

Terminal No.	Function
1	P RS 485 for connection to
2	N RS 485 bus or PC
3	5 V DC Supply for RS 485 bus
4	0 V DC

LED 300-304

LED 300 (red):	Fault trip
LED 301 (yellow):	Warning
LED 302 (green):	Power on
LED 303-304:	Communication

For PROFIBUS versions please refer to the Profibus manual available from Brook crompton.

Connection diagram - factory setting

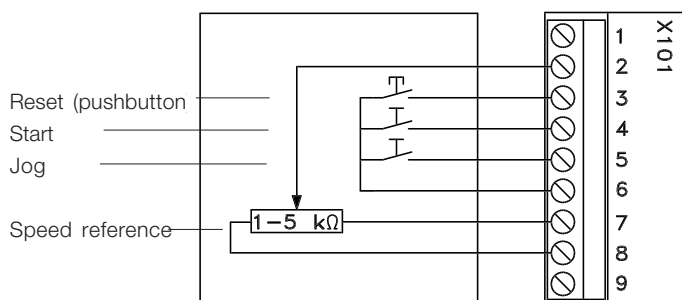

- Reset to be closed short time for resetting fault trips
- Start to be closed for changing to run mode
- Jog will run at fixed speed while closed (10 Hz)
- Speed reference (0-10 V) determines speed while in run mode

**Chapter 6**

- Description of the VSM unit ..... page 18
- Handling the VSM unit ..... page 19
- Dimensions ..... page 20
- Installation of the VSM unit ..... page 22
- Maintenance ..... page 23
- Forced ventilation units ..... page 24

■ Description

The VSM unit consists of the following parts:

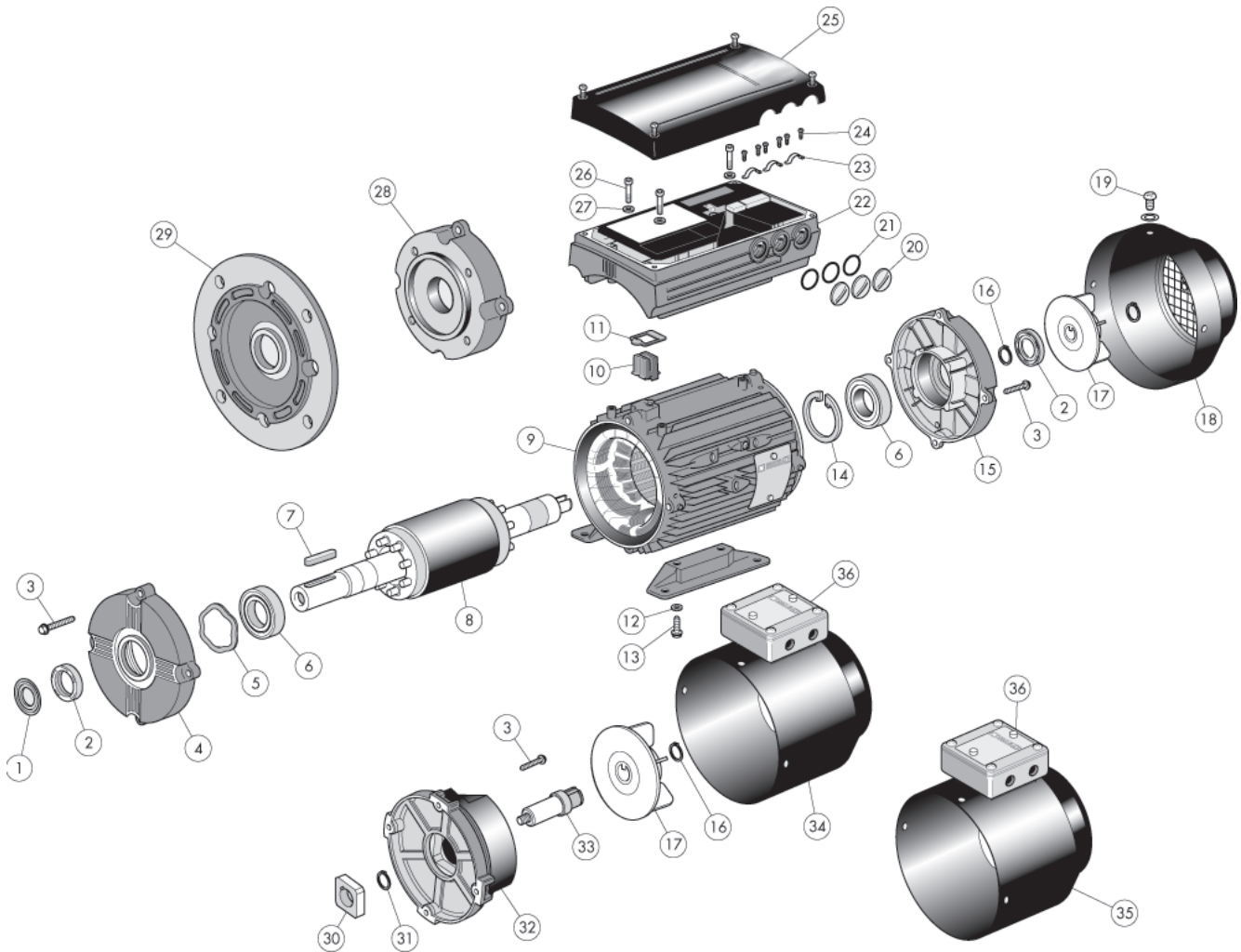

Item	Description
1	Flinger (when fitted)
2	Drive end oilseal
3	Endshield fixing bolt
4	Drive end endshield
5	Preload washer
6	Bearing
7	Shaft key
8	Rotor assembly
9	Stator assembly with or without fan
10	Connector block
11	Gasket
12	Detachable feet
13	Foot fixing bolt and washer
14	Bearing retention circlip
15	Non-drive endshield
16	Bearing circlip
17	Fan
18	Fan cover

Item	Description
19	Fan cover screw and washer
20	Screwed bung
21	O' ring
22	ISM box
23	Cable strap
24	Cable strap screws
25	ISM box lid
26	Torx screw
27	Washer
28	Face endshield
29	Flange endshield
30	Brake hub
31	Brake hub retention circlip
32	Brake and adaptor plate
33	Stub shaft
34	Brake fan cover
35	Force vent fan cover
36	Terminal box

## ■ Handling the VSM unit

Handling and lifting of VSM units must only be undertaken by qualified personnel. Full product documentation and operating instructions must be available together with tools and equipment necessary for safe working practice. Eyebolts and/or lifting trunnions supplied with the VSM unit are designed to support only the weight of the VSM unit, not the weight of the VSM unit and any auxiliary equipment attached to it. Be absolutely sure that cranes, jacks, slings and lifting beams are capable of carrying the weight of equipment to be lifted.

Where an eyebolt is provided with the motor, this should be screwed down until its shoulder is firmly against the face of the stator frame to be lifted.

VSM	approx. weight (kg.)
VSM 005	11
VSM 007	13
VSM 011	17
VSM 015	20
VSM 022	26
VSM 030	28
VSM 040	37
VSM 055	56
VSM 075	61

## ■ Bearings.

To avoid static indentation, the storage area should be vibration free. Where exposure to some vibration is unavoidable, the shaft should be locked. Bearings may be fitted with a shaft locking device which should be kept in place during storage.

Shafts should be rotated by hand, one quarter of a revolution, at weekly intervals.

Bearings are despatched from the works fully charged with lithium based grease. Shielded bearings have sufficient grease for an operating life of at least two years in normal

ambient temperatures, providing there is little or no grease leakage.

### Lubrication

Frame size	Lubrication type	Temperature range
80-132	Esso unirex N3	-10 to + 140°C

### Bearing life

Maximum hours bearing life (L<sub>na</sub>) expected at 80° C bearing temp. x 10<sup>3</sup> hours.

Frame size	3000 min <sup>-1</sup>		1500 min <sup>-1</sup>	
	Horiz.	Vert.	Horiz.	Vert.
80-90	22	22	32	32
100/112	26	26	35	35
132	26	26	35	35

L<sub>na</sub> bearing life is the adjusted, L10 life rating, taking account of: -Reliability -Material improvement -Lubrication conditions.

### Standard Bearing references and oil seals

Frame size	Mounting	Poles (2 or 4)	Bearings		Oil seals - Bore x O/D x width in mm	
			Drive end	Non-drive end	Drive end	Non-drive end
80	All	All	6204 2Z	6202 2Z	20 x 30 x 7	15 x 24 x 5
90	All	All	6205 2Z	6203 2Z	25 x 35 x 7	17 x 28 x 6
100	All	All	6206 2Z	6205 2Z	30 x 42 x 7	25 x 37 x 7
112	All	All	6206 2Z	6205 2Z	30 x 42 x 7	25 x 37 x 7
132	All	All	6208 2Z	6305 2Z	40 x 52 x 7	25 x 37 x 7

## ■ Output shafts.

Output shafts are produced from 35/40 Ton (460/540 MN/m<sup>2</sup>) tensile steel. Drive end shafts are provided with a tapped hole to DIN 332 Form D and a closed profile keyway as standard.

### Balance

All motors are dynamically balanced, to ISO 2373 with key convention to IEC 34-14.

### Inertia

VSM	J [kgm <sup>2</sup> ]	
	2 pole	4 pole
VSM 005	0.0015	0.0019
VSM 007	0.0015	0.0027
VSM 011	0.0024	0.0035
VSM 015	0.0024	0.0047
VSM 022	0.006	0.009
VSM 030	0.007	0.010
VSM 040	0.008	0.016
VSM 055	0.017	0.027
VSM 075	0.020	0.032

■ Dimensions

Foot mounting - B3

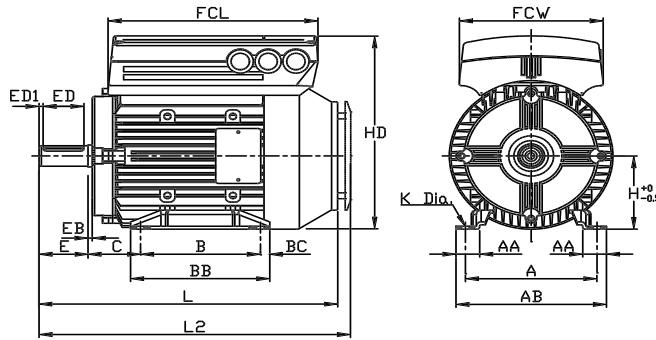

General

VSM	005	007	011	015	022	030	040	055	075
Frame size	80	80	90	90	100	100	112	132	132
A [mm]	125	125	140	140	160	160	190	216	216
B [mm]	100	100	125	125	140	140	140	140	178
C [mm]	50	50	56	56	63	63	70	89	89
H [mm]	80	80	90	90	100	100	112	132	132
K [mm]	10	10	10	10	12	12	12	12	12
AA [mm]	27	27	28	28	28	28	35	38	38
AB [mm]	157	157	165	165	184	184	218	242	242
BB [mm]	127	127	152	152	170	170	170	208	208
BC [mm]	13.5	13.5	38.5	13.5	15	15	15	53	15
L [mm]	278	278	322	322	368	368	382	489	489
L2 [mm]	298	298	342	342	397	397	410	490	490
AC [mm]	158	158	178	178	199	199	215	255	255
HD [mm]	219.5	219.5	234	234	264	264	291	335	335
EB [mm]	1.5	1.5	1.5	1.5	6	6	6	6	6
FCL [mm]	206	206	230	230	256	256	286	340	340
FCW [mm]	141	141	158	158	176	176	197	235	235

Shaft Drive End

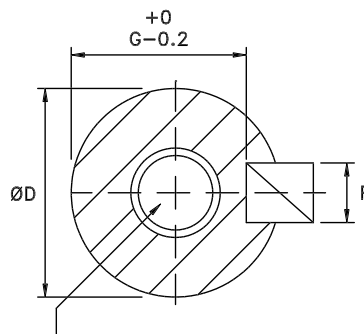

Shaft tapped  
DH x deep to  
DIN 332 Form D

VSM	005	007	011	015	022	030	040	055	075
Frame size	80	80	90	90	100	100	112	132	132
D [mm]	19	19	24	24	28	28	28	38	38
E [mm]	40	40	50	50	60	60	60	80	80
ED [mm]	32	32	40	40	50	50	50	70	70
ED1 [mm]	4	4	5	5	5	5	5	5	5
DH	M6x16	M6x16	M8x19	M8x19	M10x22	M10x22	M10x22	M12x28	M12x28
F [mm]	6	6	8	8	8	8	8	10	10
G [mm]	15.5	15.5	20	20	24	24	24	33	33

## VSM

### Flange mounting - B5, B35 (B3+B5)

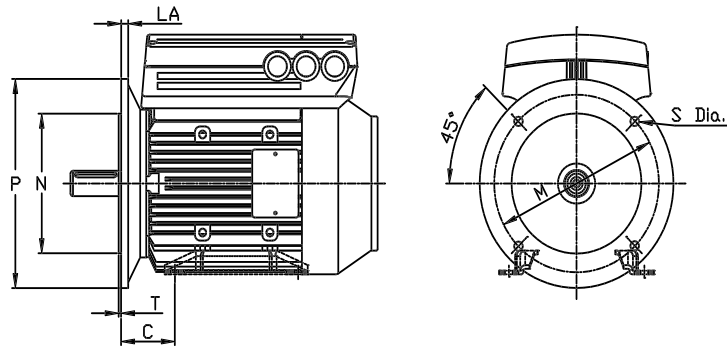

#### B5

#### VSM

		005/ 007	011/ 015	022/ 030	040	055/ 075
<b>Frame size</b>	<b>48</b>	<b>56</b>	<b>63</b>	<b>71</b>	<b>80</b>	<b>132</b>
IEC Ref.	FF85	FF100	FF115	FF130	FF165	FF265
DIN Ref.	A105	A120	A140	A160	A200	A300
M [mm]	85	100	115	130	165	265
N [mm]	70	80	95	110	130	230
P [mm]	105	120	140	160	200	300
S [mm]			10	10	12	15
T [mm]			3	3.5	3.5	4
LA [mm]			7	7	12	12

### Face mounting - B14, B34 (B3+B14)

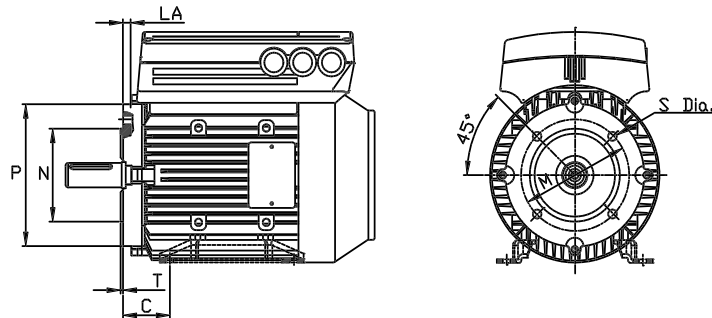

#### B14

#### VSM

		005/ 007	011/ 015	022/ 030	040	055/ 075
<b>Frame size</b>	<b>56</b>	<b>63</b>	<b>71</b>	<b>80</b>	<b>100</b>	<b>132</b>
IEC Ref.	FT65	FT75	FT85	FT100	FT130	FT215
DIN Ref.	C80	C90	C105	C120	C160	C200
M [mm]	65	75	85	100	130	165
N [mm]	50	60	70	80	95	130
P [mm]	80	90	105	120	140	200
S		M5	M6	M6	M8	M10
T [mm]		2.5	2.5	3	3	3.5
LA [mm]		9	9	9	9	14

Dimensions should not be used for installation purposes unless specially endorsed by Brook Crompton

■ Installation of the VSM unit

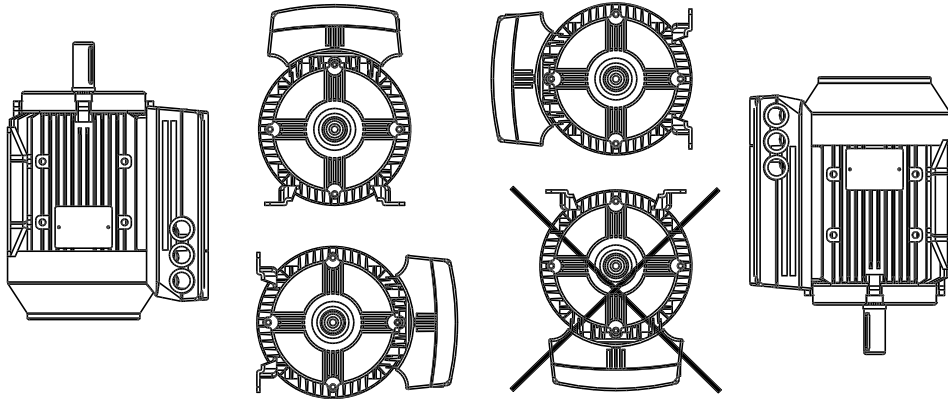

VSM units must be installed with adequate access for routine maintenance. A minimum of 0.75m of working space around the motor is recommended. Adequate space around the motor, particularly at the fan inlet (50 mm), is also necessary to facilitate airflow.

Where several VSM units are installed in close proximity, care must be taken to ensure that there is no recirculation of exhausted warm air. Foundations must be solid, rigid and level.

Fitting pinions, pulleys and couplings.

These should be bored to our standard limits and fitted on the shaft with a screwing motion. Attention must be paid to correct guarding of all moving parts.



Tapping of fittings onto the VSM unit shaft, with a hammer or mallet, causes bearing damage. This results in an increase in bearing noise and a significant reduction in bearing life.

■ Alignment

When the application calls for direct coupling, the shafts must be correctly aligned in all three planes. Bad alignment can be a major source of noise and vibration.

Allowance must be made for shaft endfloat and thermal expansion in both axial and vertical planes. It is preferable to use flexible drive couplings.

**Maximum permissible external axial and radial loads in N<sup>1</sup> - standard ball bearings**

		Horizontal shaft		Vertical shaft				
		Load towards motor	Load away from motor	Shaft up		Shaft down		
Frame size	Pole			Up	Down	Up	Down	Max. radial <sup>2</sup>
80	2	275	441	481	245	294	432	638
	4	373	549	569	343	392	520	785
90	2	412	638	598	294	373	520	824
	4	540	765	716	402	471	628	903
100	2	853	853	932	932	814	814	1207
	4	1010	1010	1118	1118	961	961	1393
112	2	853	853	932	932	814	814	1207
	4	1010	1010	1118	1118	961	961	1393
132S	2	1059	1403	1570	952	1216	1305	1785
	4	1265	1609	1825	1138	1472	1481	1972
132M	4	1256	1609	1854	1109	1501	1462	2040

<sup>1</sup> All figures are based on L<sub>na</sub> bearing life of 20,000 hours.

L<sub>na</sub> = adjusted L<sub>10</sub> life rating taking account of:-Reliability -Material improvements -Lubrication conditions

<sup>2</sup> Max. permissible radial load at end of shaft (horizontal mounting).

**Maximum permissible external axial and radial loads in N<sup>1</sup> - angular contact bearings**

		Horizontal shaft		Vertical shaft				
		Load towards motor	Load away from motor	Shaft up		Shaft down		
Frame size	Pole			load Up	load Down	load Up	load Down	Max. radial <sup>2</sup>
80	2	1375	2205	2405	1225	1470	2160	3190
	4	1865	2745	2845	1715	1960	2600	3925
90	2	2060	3190	2990	1470	1865	2600	4120
	4	2700	3825	3580	2010	2355	3140	4515
100	2	4265	4265	4660	4660	4070	4070	6035
	4	5050	5050	5590	5590	4805	4805	6965
112	2	4265	4265	4660	4660	4070	4070	6035
	4	5050	5050	5590	5590	4805	4805	6965
132S	2	5295	7015	7850	4760	6080	6525	8925
	4	6325	8045	9125	5690	7360	7405	9860
132M	4	6280	8045	9270	5545	7505	7310	10200

<sup>1</sup> All figures are based on L<sub>na</sub> bearing life of 20,000 hours.

L<sub>na</sub> = adjusted L10 life rating taking account of:-Reliability -Material improvements -Lubrication conditions

<sup>2</sup> Max. permissible radial load at end of shaft (horizontal mounting).

**■ Bolt torques**

Endshields, feet and lid should be secured with the bolt sizes and torque's detailed in the table below.

Foot fixing bolt torques

VSM Type	Frame size	Bolt diameter	Torque Nm.
005-007	80	M8 (taptite)	24-25
011-015	90	M8 (taptite)	24-25
022-030	100	M8 (taptite)	32-35
040	112	M8 (taptite)	32-35
055-075	132	M8 (taptite)	32-35

LID screws torque: 2.2 - 2.4 Nm

Endshield fixing bolt torques

VSM Type	Frame size	Bolt diameter	Torque Nm.
005-007	80	M5	5
011-015	90	M5	5
022-030	100	M6 (taptite)	8-10
040	112	M6 (taptite)	8-10
055-075	132	M6 (taptite)	8-10

**■ Maintenance**

Routine cleaning of the VSM unit

Remove the fan cover and ensure that all air inlet holes are completely free. Clean any dirt and obstructions from behind the fan and along the ribs of the frame, and between the motor and inverter part.

Periodic maintenance of motor part.

- a) Remove the inverter part, the fan cover and the fan which is keyed to the shaft extension. Loosen and remove bearing cover screws and endshield bolts/studs. The endshields should then be eased off their spigots.
- (b) The rotor can now be carefully withdrawn from the stator, taking care not to damage the stator bore and both stator and rotor windings.
- (c) Having dismantled the motor, maintenance can be carried out to remove all dirt. For this purpose, the use of an air line supplying dry compressed air under comparatively low pressure is best, as a high velocity air-stream can force dirt into the spaces between the

windings and insulation, etc. Grease-removing solvents can cause damage to impregnating varnish or insulation

- (d) The VSM unit should be re-assembled in the reverse order from dismantling, remembering to ease endshields onto bearings and spigots. DO NOT USE FORCE.
- (e) Before starting, check that the rotor revolves freely. Ensure that the electrical connections are correct.
- (f) Refit any pulley, coupling, sprocket etc. which has been removed, being particularly careful to ensure correct alignment with the driven part, as misalignment will lead to ultimate bearing trouble and shaft breakage.
- (g) When replacing screws and bolts, care should be taken to use only those with the requisite quality and tensile strength recommended by the manufacturer. These must also be of identical thread form and screw/bolt length (see the table above).

■ **Forced ventilation (FV) units**

In some applications the fan built on to the motor shaft do not give sufficient cooling for operation at low speed (see drawing on page 84). That problem is solved by mounting a FV unit.

Typical applications are for example conveyors, spindles and other constant torque (CT) applications where the customer wants a wide control range down to low speed.

The FV unit is available in 2 versions. The characteristics of the two versions are the same. The variable factors are the length and the placing of the terminal box.

The Variable speed W yields full continuous torque down to low speed with FV built on.

**Voltage range for forced ventilation (FV) units:**

Frame size:			Prefuse [A]
80	0.55 and 0.75 kW	1 phase 1 x 230V +/-6%	0.2
90-132	1.1 to 7.5 kW	3 phase 3 x 230/400V +/-6%	0.25



**NB!**

Restricted voltage range applies when the VSM unit is fitted with forced ventilation unit.

Forced ventilation units can be ordered with different supply voltages.

■ **Brake Motors**

The Variable speed W can be delivered with an electro mechanical brake, which is controlled by the frequency converter. See parameter 138 and 139 for adjustment.

Brake data:

VSM type	Frame Size	Torque Nm	Thermal capacity kJ/h	Brake inertia kgcm2
005-007	80	10	250	1.22
011-015	90	20	350	2.10
022-030	100	40	550	5
040	112	40	550	14
055-075	132	80	800	70

**Short version - only forced ventilation units:**

The terminal box is mounted on the side of the motor.

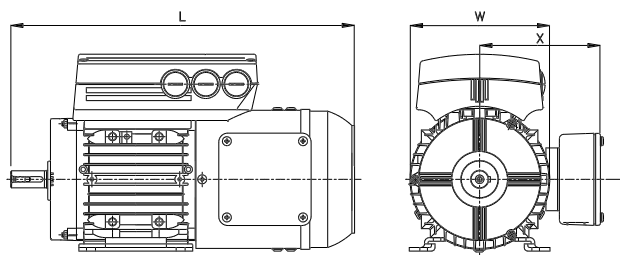

	80	90	100	112	132
L:	384	456	480	496	553
X:	138	149	161	172	192
W:	160	178	199	215	255

**Standard version - brake and forced ventilation units:**

The terminal box is mounted in line with the inverter box.

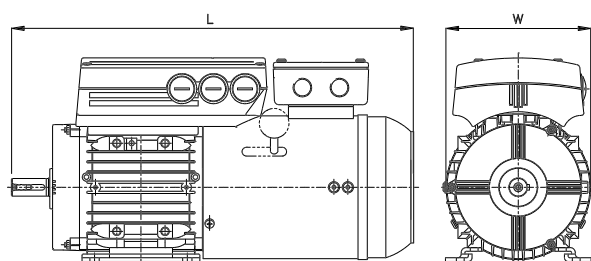

	80	90	100	112	132
L:	434	510	557	573	653
W:	160	178	199	215	255

<b>Chapter 7</b>	<ul style="list-style-type: none"> <li>■ Control panel ..... page 26</li> <li>■ Display ..... page 26</li> <li>■ Control key functions ..... page 27</li> <li>■ Display read-out state ..... page 28</li> <li>■ Display mode ..... page 28</li> <li>■ Display mode - selection of read-out state .. page 28</li> <li>■ Quick menu mode vs. the menu mode ..... page 29</li> <li>■ Quick Setup via Quick menu ..... page 29</li> <li>■ Parameter selection ..... page 29</li> <li>■ Menu mode ..... page 30</li> <li>■ Parameter groups ..... page 30</li> <li>■ Changing data ..... page 30</li> <li>■ Changing a text value ..... page 30</li> <li>■ Infinitely variable change of numeric data value ..... page 31</li> <li>■ Menu structure ..... page 32</li> <li>■ Service plug kit ..... page 33</li> <li>■ Plug kit ..... page 33</li> <li>■ Remote mounting kit ..... page 33</li> <li>■ Local Operation Pad (LOP) ..... page 34</li> </ul>
------------------	---

■ **Control panel**

The VSM unit optionally features a Local Control Panel - LCP 2 which makes up a complete interface for operation and monitoring of the VSM.



**NB!**

The LCP from the VLT 5000 Series (code number 175Z0401) cannot be used for the VSM unit. However, the general LCP 2 (code number 175N0131) can be used for both the VSM, VLT 2800 and the VLT 5000 Series.

■ **LCP installation**

The LCP 2 is connected to the terminal X100, 1-4 (see separate instruction MI.03.AX.YY).

■ **LCP functions**

The functions of the control panel can be divided into three groups:

- display
- keys for changing program parameters
- keys for local operation

All data are indicated by means of a 4-line alpha-numeric display, which in normal operation is able to show 4 measurements and 3 operating conditions continuously. During programming, all the information required for quick, effective parameter

Setup of the VSM unit will be displayed. As a supplement to the display, there are three LEDs for voltage, warning and alarm.

All program parameters of the VSM unit can be changed immediately from the control panel, unless this function has been blocked via parameter 018.

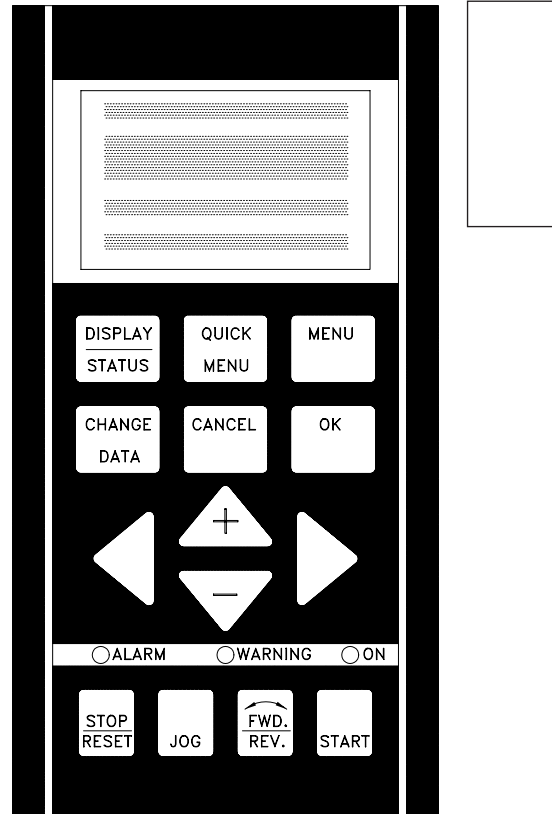

■ **Display**

The LCD-display has rear lighting and a total of 4 alpha-numeric lines together with a box that shows the direction of rotation (arrow) and the chosen Setup as well as the Setup in which programming is taking place if that is the case.

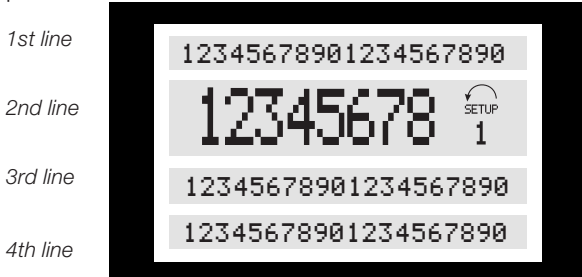

**1st line** shows up to 3 measurements continuously in normal operating status or a text which explains the 2nd line.

**2nd line** shows a measurement with related unit continuously, regardless of status (except in the case of alarm/warning).

**3rd line** is normally blank and is used in the menu mode to show the selected parameter number or parameter group number and name.

**4th line** is used in operating status for showing a status text or in data change mode for showing the value of the selected parameter.

An arrow indicates the direction of rotation of the motor. Furthermore, the Setup which has been selected as the Active Setup in parameter 004 is shown. When programming another Setup than the Active Setup, the number of the Setup which is being programmed will appear to the right. This second Setup number will flash.

■ **LEDs**

At the bottom of the control panel is a red alarm LED and a yellow warning LED, as well as a green voltage LED.



If certain threshold values are exceeded, the alarm and/or warning lamp lights up together with a status and alarm text on the control panel.

The voltage LED is activated when the VSM unit receives voltage; at the same time the rear lighting of the display will be on.

■ **Control keys**

The control keys are divided into functions. This means that the keys between display and indicator LEDs are used for parameter Setup, including choice of display indication during normal operation.

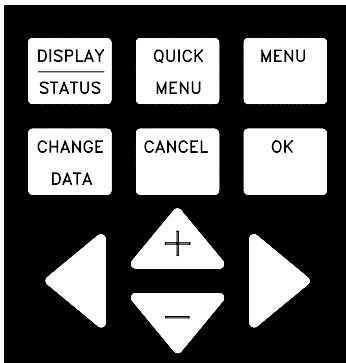

Keys for local control are found under the indicator LEDs.

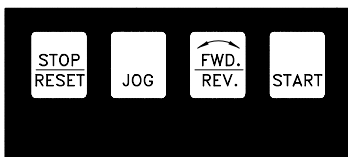

[CHANGE DATA] is used for changing the parameter selected either in the Menu mode or the Quick menu mode.



[CANCEL] is used if a change of the selected parameter is not to be carried out.



[OK] is used for confirming a change of the parameter selected.



[+/-] is used for selecting parameter and for changing the chosen parameter or for changing the read out in line 2.

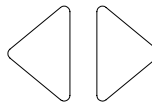

[<>] is used for selecting group and to move the cursor when changing numerical parameters.



[STOP / RESET] is used for stopping or for resetting the VSM unit after a drop-out (trip). Can be selected via parameter 014 to be active or inactive. If stop is activated, line 2 will flash, and [START] must be activated.



**NB!**

Pressing [STOP/RESET] will prevent the unit from running also with disconnected LCP 2. Restarting is only possible via the LCP 2 [START] key.

■ **Control key functions**



[DISPLAY / STATUS] is used for selecting the mode of display or for changing back to Display mode from either the Quick menu mode or the Menu mode.



[QUICK MENU] is used for programming the parameters that belong under the Quick menu mode. It is possible to switch directly between Quick menu mode and Menu mode.



[MENU] is used for programming all parameters. It is possible to switch directly between Menu mode and Quick menu mode.



[JOG] overrides the output frequency to a preset frequency while the key is kept down. Can be selected via parameter 015 to be active or inactive.



[FWD / REV] changes the direction of rotation of the motor, which is indicated by means of the arrow on the display although only in Local. Can be selected via parameter 016 to be active or inactive (parameter 013 must be set to [1] or [3] and parameter 200 set to [1]).



[START] is used for starting the VSM unit after stop via the [Stop] key. Is always active, but cannot override a stop command given via the terminal strip.

## VSM



**NB!**

If the keys for local control have been selected as active, they will remain active both when the frequency has been set for *Local Control* and for *Remote Control* via parameter 002, although with the exception of [FWD/REV], which is only active in Local operation.



**NB!**

If no external stop function has been selected and the [STOP] key has been selected as inactive via parameter 014, the VSM unit can be started and can only be stopped by disconnecting the voltage to the motor.

■ **Display read-out state**

The display read-out state can be varied - see the list on page 32 - depending on whether the VSM unit is in normal operation or is being programmed.

■ **Display mode**

In normal operation, up to 4 different operating variables can be indicated continuously: 1,1 and 1,2 and 1,3 and 2, and in line 4 the present operating status or alarms and warnings that have arisen.



■ **Display mode - selection of read-out state**

There are three options in connection with the choice of read-out state in the Display mode - I, II and III. The choice of read-out state determines the number of operating variables read out.

Read-out state:	I:	II:	III:
Line 1	Description for operating variable in line 2	Data value for 3 operating variables in line 1	Description for 3 operating variables in line 1

The table below gives the units linked to the variables in the first and second line of the display (see parameter 009).

Operating variable:	Unit:
Reference	[%]
Reference	[unit]*
Feedback	[unit]*
Frequency	[Hz]
Frequency x scaling	[-]
Motor current	[A]
Torque	[%]
Power	[kW]
Power	[HP]
Motor voltage	[V]
DC-link voltage	[V]
FC thermal	[%]
Hours run	[Hours]
Input status, dig. Input	[Binary code]
External reference	[%]
Status word	[Hex]
Heat sink temp.	[°C]
Alarm word	[Hex]
Control word	[Hex]
Warning word 1	[Hex]
Warning word 2	[Hex]
Analog input 1	[mA]
Analog input 2	[V]

\*) Select in parameter 416. The unit is shown in readout state 1 line 1 otherwise 'U' is shown.

Operating variables 1,1 and 1,2 and 1,3 in the first line, and operating variable 2 in the second line are selected via parameter 009, 010, 011 and 012.

- Read-out state I: This read-out state is standard after starting up or after initialisation.

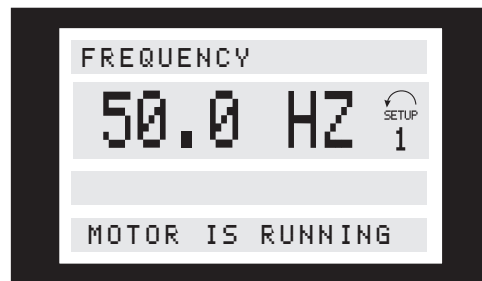

Line 2 gives the data value of an operating variable with related unit, and line 1 provides a text which explains line 2, cf. table. In the example, Frequency has been selected as variable via parameter 009. During normal operation another variable can immediately be read out by using the [+/-] keys.

- Read-out state II:  
Switching between read-out states I and II is effected by pressing the [DISPLAY / STATUS] key.

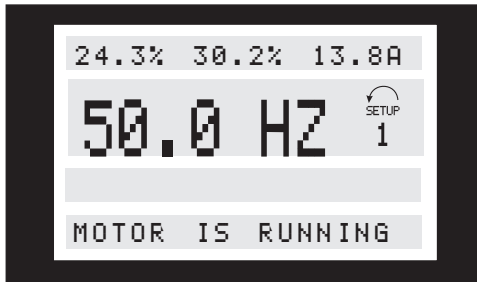

In this state, data values for four operating values are shown at the same time, giving the related unit, cf. table. In the example, Reference, Torque, Current and Frequency are selected as variables in the first and second line.

- Read-out state III:  
This read-out state can be held as long as the [DISPLAY/STATUS] key is pressed. When the key is released, the system switches back to Read-out state II, unless the key is pressed for less than approx. 1 sec..

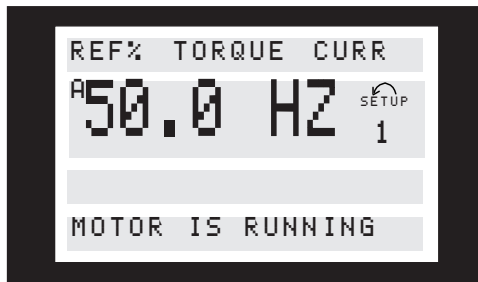

This is where parameter names and units for operating variables in the first line are given - operating variable 2 remains unchanged.

#### ■ Quick menu mode versus Menu mode

VSM units can be used for practically all assignments, which is why the number of parameters is quite large. Also, this series offers a choice between two programming modes - a Menu mode and a Quick menu mode.

- The Quick menu takes the user through a number of parameters that may be enough to get

the motor to run nearly optimally, if the factory setting for the other parameters takes the desired control functions into account, as well as the configuration of signal inputs/outputs (control terminals).

- The Menu mode makes it possible to select and change all parameters at the user's option. However, some parameters will be "missing", depending on the choice of configuration (parameter 100), e.g. open loop hides all the PID parameters.

In addition to having a name, each parameter is linked up with a number which is the same regardless of the programming mode. In the Menu mode, the parameters are divided into groups, with the first digit of the parameter number (from the left) indicating the group number of the parameter in question.

Regardless of the mode of programming, a change of a parameter will take effect and be visible both in the Menu mode and in the Quick menu mode.

#### ■ Quick Setup via Quick menu

The Quick Setup starts with pressing the [QUICK MENU] key, which brings out the following read-out on the display:



At the bottom of the display, the parameter number and name are given together with the status/value of the first parameter under Quick Setup. The first time the [Quick Menu] key is pressed after the unit has been switched on, the read-outs will always start at pos. 1 - see table below.

#### ■ Parameter selection

The selection of parameter is effected by means of the [+/-] keys. The following parameters are accessible:

Pos.:No.:	Parameter:	Unit:
1 001	Language	
2 200	Direction of rotation	
3 101	Torque characteristic	
4 204	Min. reference	[Hz]
5 205	Max. reference	[Hz]
6 207	Ramp up time	[sec.]
7 208	Ramp down time	[sec.]
8 002	Local/remote control	
9 003	Local reference	
10 500	Bus address	

■ **Menu mode**

The Menu mode is started by pressing the [MENU] key, which produces the following read-out on the display:

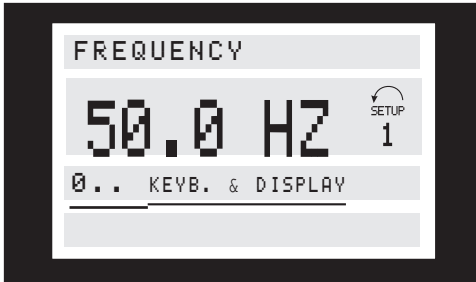

Line 3 on the display shows the parameter group number and name.

■ **Parameter groups**

In the Menu mode the parameters are divided into groups. Selection of parameter group is effected by means of the [<>] keys.

The following parameter groups are accessible:

Group no.	Parameter group:
0	Operation & Display
1	Load & Motor
2	References & Limits
3	Inputs & Outputs
4	Special functions
5	Serial communication
6	Technical functions

\*For information on parameter group 800 and 900 for PROFIBUS, please see the VM Profibus manual

■ **Changing data**

Regardless of whether a parameter has been selected under the Quick menu or the Menu mode, the procedure for changing data is the same. Pressing the [CHANGE DATA] key gives access to changing the selected parameter, following which the underlining in line 4 will flash on the display. The procedure for changing data depends on whether the selected parameter represents a numerical data value or a text value.

■ **Changing a text value**

If the selected parameter is a text value, the text value is changed by means of the [+/-] keys.

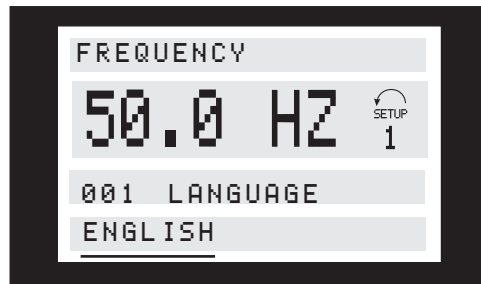

The bottom display line shows the text value that will be entered (saved) when acknowledgement is given [OK].

When the desired parameter group has been selected, each parameter can be chosen by means of the [+/-] keys:

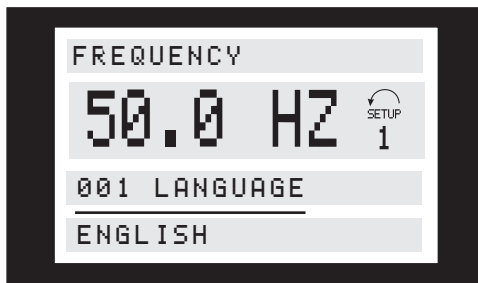

The 3rd line of the display shows the parameter number and name, while the status/value of the selected parameter is shown in line 4.

■ **Infinitely variable change of numeric data value**

If the chosen parameter represents a numeric data value, a digit is first selected by means of the [←>] keys.

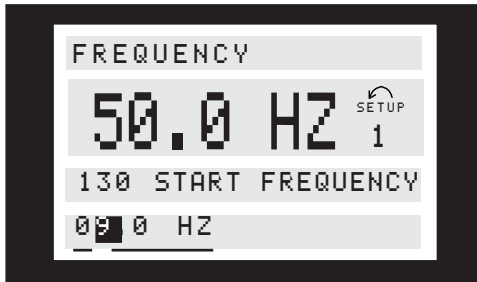

Then the chosen digit is changed infinitely variably by means of the [+/-] keys:

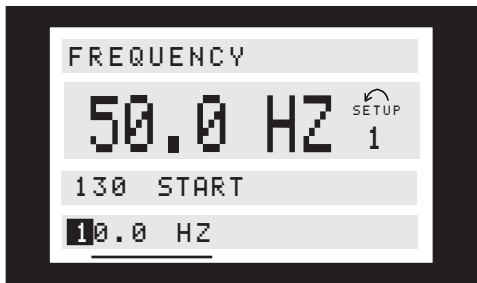

The chosen digit is indicated by the digit flashing. The bottom display line shows the data value that will be entered (saved) when signing off with [OK].

■ Menu structure

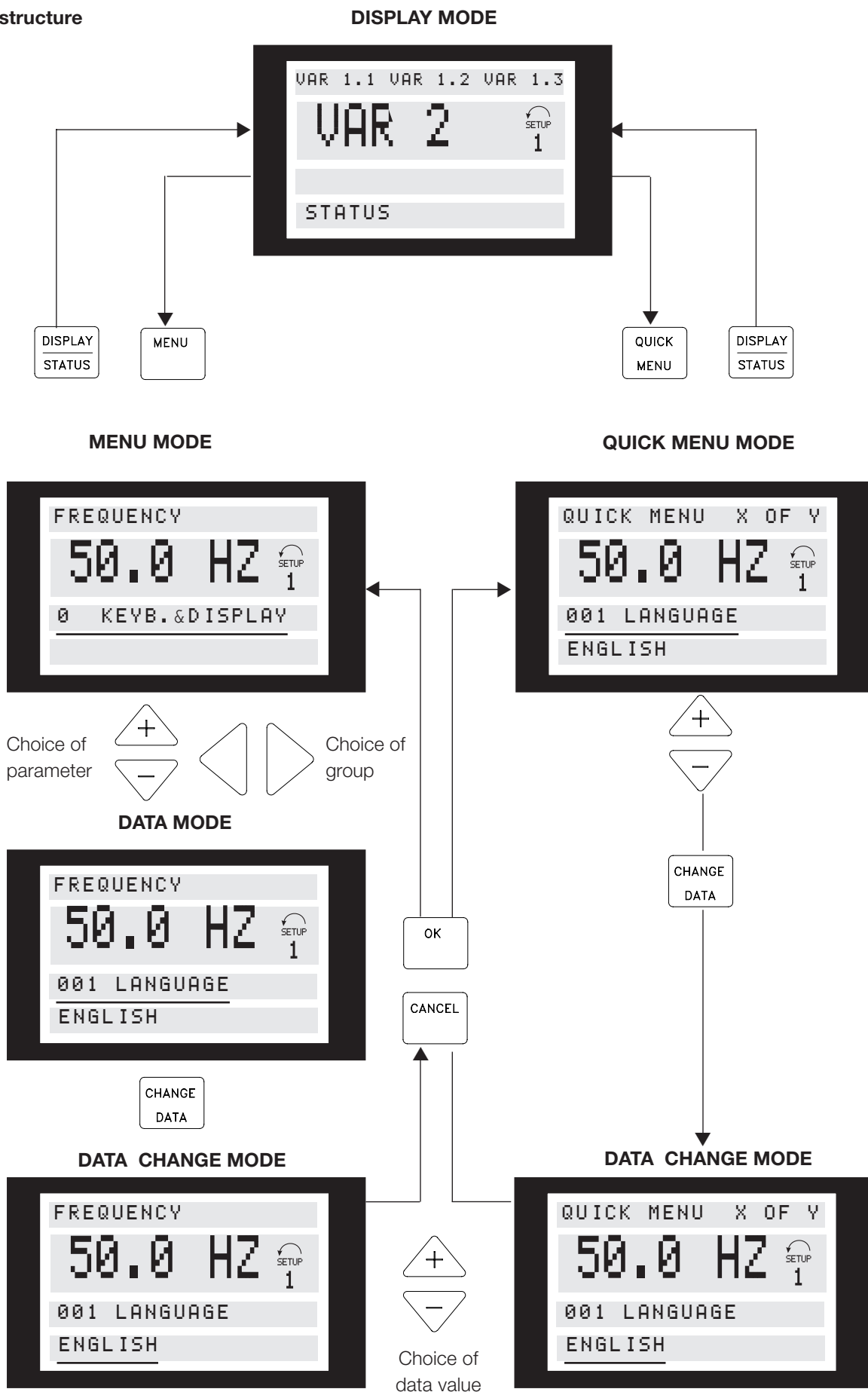

■ Service plug kit

**Purpose:**

To run LCP2 and PROFIBUS at the same time.  
The service plug can be used with Variable speed W of serial number 03Gxxx and software version as from 2.03.  
Used together with cable for plug kit 175N0162.

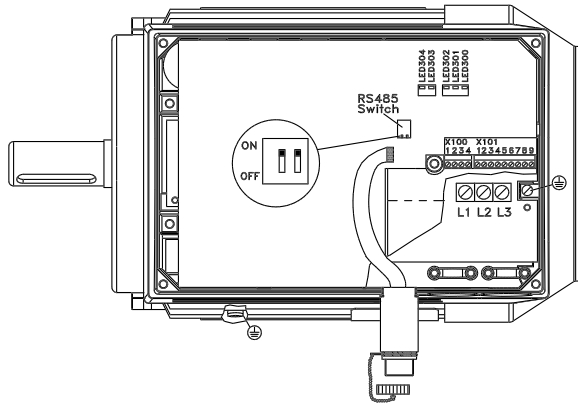

■ Plug kit

**Purpose**

To make a pluggable connection between LCP 2 and VSM.  
Used together with cable for plug kit 175N0162.

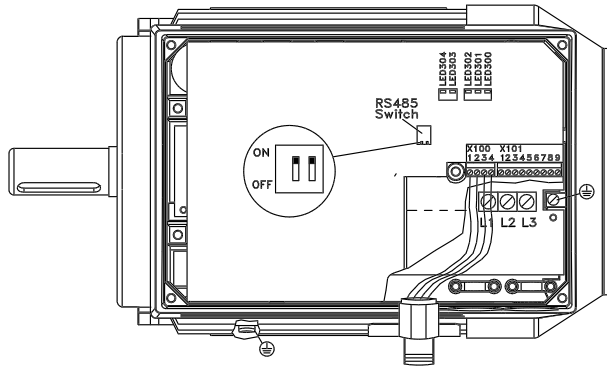

■ Remote mounting kit

**Connections:**

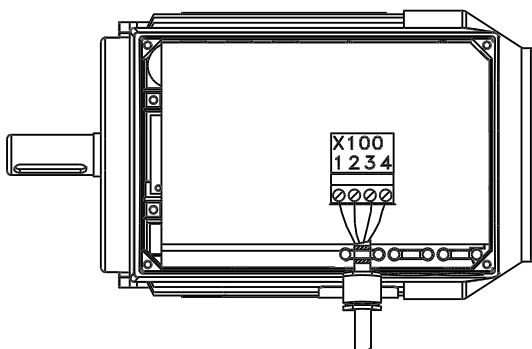

Colour of wire/	Terminal X100/	D-sub pin
yellow	1	8
green	2	9
red	3	2
blue	4	3

■ Remote mounting kit cont.

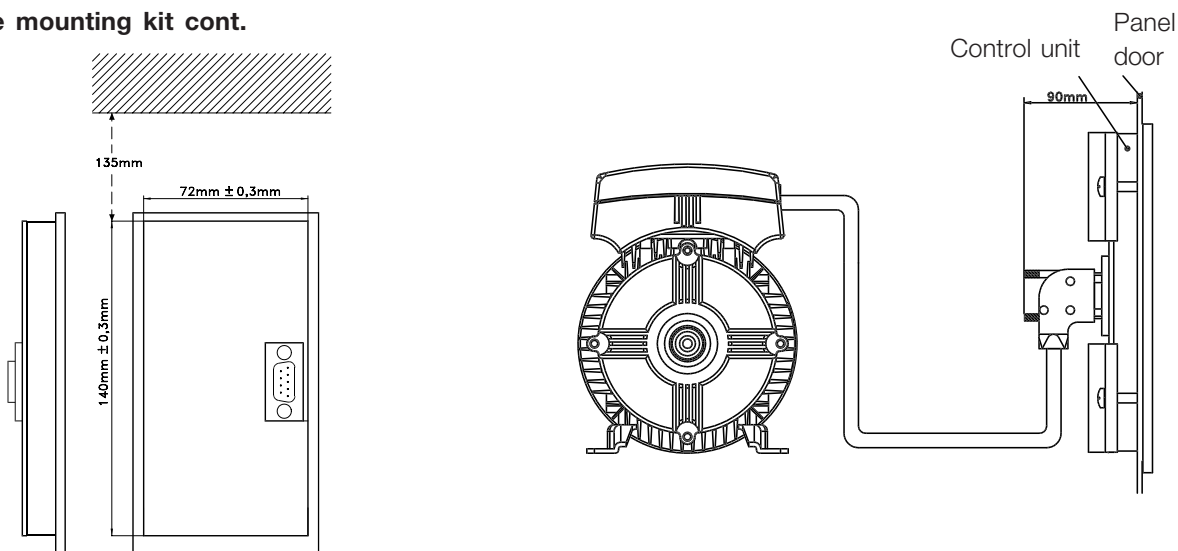

■ Local Operation Pad (LOP)

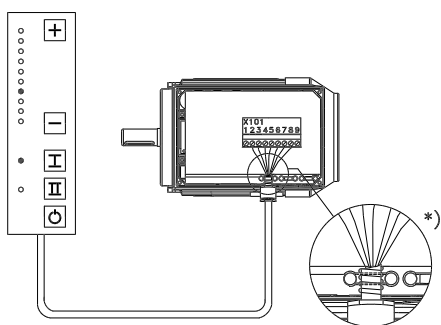

Wiring

Colour of wire	Terminal	Function
White	2	Reference
Brown	3	Reset
Purple or Grey	4	See table under button
Green	5	See table under button
Red	6	+24V
Yellow	7	+10V
Blue	8	Ground

Use the +/- keys to set reference

Function/settings	Key  (Start)	Key  (Start)	Key  (Stop)
<b>Default - Dual speed operation (connect purple wire):</b> No changes to factory setting.	Run on set reference (+/-)	Run on 10 Hz** jog speed	Stop (and reset* - if trip)
<b>Function 2 - Dual mode operation (connect purple wire):</b> Select desired modes of operation in Setups 1 and 2 (use para. 4-6) Parameter 335 = 18 (select Setup)	Run with Setup 1	Run with Setup 2	Stop (and reset* - if trip)
<b>Function 3 - Dual direction operation (connect grey wire):</b> Parameter 335 = 10 (start reversing) Parameter 200 = 1 (both directions)	Run forward	Run reverse	Stop (and reset* - if trip)

\*If no reset is required, do not connect the brown wire  
\*\*or set parameter 213

At power up the unit will always be in stop mode. Set reference will be stored during power down. If permanent start mode is desired, connect terminal 6 to terminal 4 and do not connect purple/grey wire to terminal 4. This means the stop function on LOP is disabled.



**NB!**  
After fitting, cut off or isolate excess wire.

**Chapter 8**

- Operation and Display ..... page 36
- Load and motor ..... page 42
- References and limits ..... page 45
- Inputs and outputs ..... page 50
- Special functions ..... page 56
- Serial communication ..... page 61
- Technical functions ..... page 67

---

**VSM**

---

**001 Language  
(LANGUAGE)**
**Settings:**

★ English (ENGLISH)	[0]
German (DEUTSCH)	[1]
French (FRANCAIS)	[2]
Danish (DANSK)	[3]
Spanish (ESPAÑOL)	[4]
Italian (ITALIANO)	[5]

State when delivered may vary from factory setting.

**Function:**

The choice in this parameter defines the language to be used on the display.

**Description of choice:**

There is a choice of *English* [0], *German* [1], *French* [2], *Danish* [3], *Spanish* [4] and *Italian* [5].

**002 Local/remote control  
(OPERATION SITE)**
**Settings:**

★ Remote control (REMOTE)	[0]
Local control (LOCAL)	[1]

**Function:**

There is a choice of two methods of controlling the VSM unit: *Remote control* [0] and *Local control* [1].

**Description of choice:**

If *Remote control* [0] is selected, the VSM unit can be controlled via:

1. The control terminals or the serial communication port .
2. The [START] key. However, this cannot overrule Stop commands (also start-disable) entered via the digital inputs or the serial communication port.
3. The [STOP], [JOG] and [RESET] keys, provided that these are active (see parameters 014, 015 and 017).

If *Local control* [1] is selected, the VSM unit can be controlled via:

1. The [START] key. However, this cannot override Stop commands on the digital terminals (if [2] or [4] has been selected in parameter 013).
2. The [STOP], [JOG] and [RESET] keys, provided that these are active (see parameters 014, 015 and 017).
3. The [FWD/REV] key, provided that this has been activated in parameter 016 and that in

★ = factory setting. ( ) = display text [ ] = value for use in communication via serial communication port

parameter 013 a choice of [1] or [3] has been made.

4. Via parameter 003 the local reference can be controlled by means of the "Arrow up" and "Arrow down" keys.

**003 Local reference  
(LOCAL REFERENCE)**
**Settings:**

Par 013 set for [1] or [2]:

$$0 - f_{MAX} \quad \star 000.000$$

Par 013 set for [3] or [4] and par. 203 = [0] set for:

$$Ref_{MIN} - Ref_{MAX} \quad \star 000.000$$

Par 013 set for [3] or [4] and par. 203 = [1] set for:

$$-Ref_{MAX} - + Ref_{MAX} \quad \star 000.000$$

**Function:**

This parameter allows manual setting of the desired reference value (speed or reference for the selected configuration, depending on the choice made in parameter 013).

The unit follows the configuration selected in parameter 100, provided that *Process regulation, closed loop* [3] has been selected.

**Description of choice:**

*Local* [1] must be selected in parameter 002 for this parameter to be used.

The set value is saved in the case of a voltage drop-out, see parameter 019.

In this parameter Data Change Mode is not exited automatically (after time out).

Local reference cannot be set via the serial communication port.



Warning: Since the value set is remembered after the power has been cut, the motor may start without warning when the power is reinstated; if parameter 019 is changed to *Auto restart*, use *saved ref.* [0].

**004 Active Setup (ACTIVE SETUP)**

**Settings:**

Factory Setup (FACTORY SETUP)	[0]
★ Setup 1 (SETUP 1)	[1]
Setup 2 (SETUP 2)	[2]
Multi Setup (MULTI SETUP)	[5]

**Function:**

The choice in this parameter defines the Setup number you want to control the functions of the VSM unit.

All parameters can be programmed in two individual parameter Setups, Setup 1 and Setup 2. In addition, there is a pre-programmed Setup, called Factory Setup, that cannot be modified.

**Description of choice:**

*Factory Setup* [0] contains the factory data. Can be used as a data source if the other Setups are to be returned to a known state.

Parameters 005 and 006 allow copying from one Setup to the other.

*Setups 1* [1] and *2* [2] are two individual Setups that can be selected as required.

*Multi-Setup* [5] is used if remote-mounting switching between Setups is desired. Terminals 2, 3, 4, and 5 as well as the serial communication port can be used for switching between Setups.

**005 Programming Setup (EDIT SETUP)**

**Settings:**

Factory Setup (FACTORY SETUP)	[0]
Setup 1 (SETUP 1)	[1]
Setup 2 (SETUP 2)	[2]
★ Active Setup (ACTIVE SETUP)	[5]

**Function:**

The choice is of the Setup in which programming (change of data) is to occur during operation. It is possible to programme the two Setups independently of the Setup selected as the Active Setup (selected in parameter 004).

**Description of choice:**

*The Factory Setup* [0] contains the factory data and can be used as a data source if the other Setups are to be returned to a known state.

*Setups 1* [1] and *2* [2] are individual Setups which can be used as required. They can be programmed freely, regardless of the Setup selected as the Active Setup and thus controlling the functions of the VSM unit.



**NB!**

If a general change of data or a copying to the Active Setup is effected, this immediately affects the functioning of the unit.

**006 Copying of Setups (SETUP COPY)**

**Settings:**

★ No copying (NO COPY)	[0]
Copy to Setup 1 from # (COPY TO SETUP 1)	[1]
Copy to Setup 2 from # (COPY TO SETUP 2)	[2]
Copy to Setup all from # (COPY TO ALL)	[5]

# = the Setup selected in parameter 005

**Function:**

A copy is made from the Setup selected in parameter 005 to one of the other Setups or to all the other Setups simultaneously.



**NB!**

Copying is only possible in Stop Mode (motor stopped on a Stop command).

Copying will take max. 3 seconds and has ended when parameter 006 has returned to value 0.

★ = factory setting. ( ) = parameter window text. [ ] = value for use in communication via serial communication port

**007 LCP copy (LCP COPY)**

Settings:

- ★ No copying (NO COPY) [0]
- Upload all parameters (UPLOAD ALL PARAM) [1]
- Download all parameters (DOWNLOAD ALL) [2]
- Download power-independent par.  
(DOWNLOAD SIZE INDEP.) [3]

Function:

Parameter 007 is used if it is desired to use the integrated copying function of the control panel. You can therefore easily copy parameter value(s) from one VSM unit to another.

Description of choice:

Select *Upload all parameters* [1] if all parameter values are to be transmitted to the control panel. Select *Download all parameters* [2] if all transmitted parameter values are to be copied to the VSM unit on which the control panel has been mounted. Select *Download power-independent par.* [3] if only the power-independent parameters are to be downloaded. This is used if downloading to a VSM unit that has a different rated power than the one from where the parameter Setup originates.



**NB!**

Uploading/Downloading can only be carried out in the Stop mode and only between units with the same major database version (see par. 626 value major.minor)

**008 Display scaling of motor frequency (FREQUENCY SCALE)**

Settings:

- 0.01 - 100.00 [ - 10000]
- ★ 1.00 [100]

Function:

This parameter chooses the factor to be multiplied by the motor frequency,  $f_m$ , for presentation in the display, when parameters 009-012 have been set for Frequency x Scaling [5].

Description of choice:

Set the desired scaling factor.

**009 Display line 2 (DISPLAY LINE 2)**

Settings:

- None [0]
- Reference [%] (REFERENCE [%]) [1]
- Reference [unit] (REFERENCE [UNIT]) [2]
- Feedback [unit] (FEEDBACK [UNIT]) [3]
- ★ Frequency [Hz] (FREQUENCY [Hz]) [4]
- Frequency x Scaling [-] (FREQUENCY X SCALE) [5]
- Motor current [A] (MOTOR CURRENT [A]) [6]
- Torque [%] (TORQUE [%]) [7]
- Power [kW] (POWER [kW]) [8]
- Power [HP] (POWER [hp] [US]) [9]
- Motor voltage [V] (MOTOR VOLTAGE [V]) [11]
- DC link voltage [V] (DC LINK VOLTAGE [V]) [12]
- Thermal load, VSM [%] (FC THERMAL [%]) [14]
- Hours run [Hours] (RUNNING HOURS) [15]
- Digital input [Binary code] (DIGITAL INPUT [BIN]) [16]
- External reference [%] (EXTERNAL REF [%]) [21]
- Status word [Hex] (STATUS WORD [HEX]) [22]
- Heat sink temp. [°C] (HEATSINK TEMP [°C]) [25]
- Alarm word [Hex] (ALARM WORD [HEX]) [26]
- Control word [Hex] (CONTROL WORD [HEX]) [27]
- Warning word 1 [Hex] (WARNING WORD 1 [HEX]) [28]
- Warning word 2 [Hex] (WARNING WORD 2 [HEX]) [29]
- Analog input 1 [mA] (ANALOG INPUT 1 [mA]) [30]
- Analog input 2 [V] (ANALOG INPUT 2 [V]) [31]

Function:

This parameter allows a choice of the data value to be displayed in line 2 of the display. Parameters 010-012 enable the use of three additional data values to be displayed in line 1.



**NB!**

In parameter 009, "none" [0] cannot be selected.

Description of choice:

**Reference [%]** corresponds to the total reference (sum of digital/analogue/preset/bus/freeze ref./catch-up and slow-down).

**Reference [unit]** gives the sum of the references using the unit stated on the basis of configuration in parameter 100 (Hz, Hz and rpm).

**Feedback [unit]** gives the status value of terminal 1 and 2 using the unit/scale selected in parameter 414, 415 and 416.

**Frequency [Hz]** gives the motor frequency, i.e. the output frequency to the motor.

★ = factory setting. ( ) = display text [ ] = value for use in communication via serial communication port

**Frequency x Scaling [-]** corresponds to the present motor frequency  $f_M$  multiplied by a factor (scaling) set in parameter 008.

**Motor current [A]** states the phase current of the motor measured as effective value.

**Torque [%]** gives the current motor load in relation to the rated motor torque.

**Power [kW]** states the actual power consumed by the motor in kW.

**Power [HP]** states the actual power consumed by the motor in HP.

**Motor voltage [V]** states the voltage supplied to the motor.

**DC link voltage [V]** states the intermediate circuit voltage in the FC motor.

**Thermal load, FC [%]** states the calculated/estimated thermal load on the VSM unit. 100% is the cut-out limit.

**Hours run [Hours]** states the number of hours that the motor has run since the latest reset in parameter 619.

**Digital input [Binary code]** states the signal states from the 4 digital terminals (2, 3, 4 and 5). Input 5 corresponds to the bit at the far left. '0' = no signal, '1' = connected signal.

**External reference [%]** gives the sum of the external reference as a percentage (the sum of analogue/pulse/bus).

**Status word [Hex]** gives the status word sent via the serial communication port in Hex code from the VSM unit.

**Heat sink temp. [°C]** states the present heat sink temperature of the FC motor. The cut-out limit is  $90 \pm 5^\circ\text{C}$ ; cutting back in occurs at  $60 \pm 5^\circ\text{C}$ .

**Alarm word [Hex]** indicates one or several alarms in a Hex code. See page 66.

**Control word. [Hex]** indicates the control word for the FC motor. See *Serial communication*.

**Warning word 1. [Hex]** indicates one or more warnings in a Hex code. See page 66 for further information.

**Warning word 2. [Hex]** indicates one or more status states in a Hex code. See page 66 for further information.

**Analog input 1 [mA]**, states the signal value on terminal 1.

**Analog input 2 [V]**, states the signal value on terminal 2.

**010 Display line 1.1 (DISPLAY LINE 1.1)**

Value:

★ Reference [%] [1]

See parameter 009.

Function:

This parameter enables a choice of the first of three data values to be shown on the display, line 1, position 1.

For display read-outs, press the [DISPLAY/STATUS] button, see also page 28.

Description of choice:

There is a choice of 24 different data values, see parameter 009.

**011 Display line 1.2 (DISPLAY LINE 1.2)**

Value:

★ Motor current [A] [6]

See parameter 009

Function:

This parameter enables a choice of the second of the three data values to be shown on the display, line 1, position 2.

For Display read-outs, press the [DISPLAY/STATUS] button, see also page 28.

Description of choice:

There is a choice of 24 different data values, see parameter 009.

**012 Display line 1.3 (DISPLAY LINE 1.3)**

Value:

★ Power [kW] [8]

See parameter 009

Function:

This parameter enables a choice of the third of the three data values to be shown on the display, line 1, position 3.

Display read-outs are made by pressing the [DISPLAY/STATUS] button, see also page 28.

Description of choice:

There is a choice of 24 different data values, see parameter 009.

★ = factory setting. ( ) = display text [ ] = value for use in communication via serial communication port

**013 Local Control/Configuration as parameter 100 (LOCAL CTRL/CONFIG.)**

Value:	
Local not active (DISABLE)	[0]
LCP control and open loop. (LCP CTRL/OPEN LOOP)	[1]
LCP digital control and open loop. (LCP+DIG CTRL/OP.LOOP)	[2]
LCP control/as parameter 100. (LCP CTRL/AS P100)	[3]
★ LCP digital control/as parameter 100. (LCP+DIG CTRL/AS P100)	[4]

**Function:**

This is where the desired function is to be selected if Local control has been chosen in parameter 002. See also the description of parameter 100.

**Description of choice:**

If *Local not active* [0] is selected, a possible setting of *Local reference via parameter 003* is blocked.

It is only possible to change to *Local not active* [0] from one of the other setting options in parameter 013, when the VSM unit has been set to *Remote control* [0] in parameter 002.

*LCP control and open loop* [1] is used when the speed is to be adjustable (in Hz) via parameter 003, when the VSM unit has been set to *Local control* [1] in parameter 002.

If parameter 100 has not been set to *Speed regulation open loop* [0], switch to *Speed regulation open loop* [0].

*LCP digital control and open loop* [2] functions as *LCP control and open loop* [1], the only difference being that when parameter 002 has been set to *Local operation* [1], the motor is controlled via the digital inputs.

*LCP control/as parameter 100* [3] is selected if the reference is to be set via parameter 003.

*LCP digital control/as parameter 100* [4] functions as *LCP control/as parameter 100* [3], although, when parameter 002 has been set to *Local operation* [1], the motor may be controlled via the digital inputs.



**NB!**

Shift from *Remote control* to *LCP digital control and open loop*:

The present motor frequency and direction of rotation must be maintained. If the present direction of rotation does not correspond to the reversing signal (negative reference), the motor frequency  $f_M$  will be set at 0 Hz.

Shift from *LCP digital control and open loop* to *Remote control*:

The selected configuration (parameter 100) will be active. Shifts are effected without any abrupt movement.

Shift from *Remote control* to *LCP control/as parameter 100* or *LCP digital control/as parameter 100*.

The present reference will be maintained. If the reference signal is negative, the local reference will be set at 0.

Shift from *LCP control/as parameter 100* or *LCP remote control as parameter 100* to *Remote control*.

The reference will be replaced by the active reference signal from the remote control.

**014 Local stop (LOCAL STOP)**

Value:	
Not possible (DISABLE)	[0]
★ Possible (ENABLE)	[1]

**Function:**

This parameter disables/enables the local stop function in question from the control panel. This key is used when parameter 002 has been set for *Remote control* [0] or *Local* [1].

**Description of choice:**

If *Disable* [0] is selected in this parameter, the [STOP] key will be inactive.



**NB!**

If *Enable* is selected, the [STOP] key overrules all Start commands.

★ = factory setting. ( ) = display text [ ] = value for use in communication via serial communication port

**015 Local jog (LOCAL JOGGING)**

**Value:**

- ★ Not possible (DISABLE) [0]
- Possible (ENABLE) [1]

**Function:**

In this parameter, the jog function can be enabled/disabled on the control panel.

**Description of choice:**

If *Disable* [0] is selected in this parameter, the [JOG] key will be inactive.

**016 Local reversing (LOCAL REVERSING)**

**Value:**

- ★ Not possible (DISABLE) [0]
- Possible (ENABLE) [1]

**Function:**

In this parameter, the reversing function can be enabled/disabled on the control panel. This key can only be used if parameter 002 has been set to *Local operation* [1] and parameter 013 to *LCP control with open loop* [1] or *LCP control as parameter 100* [3].

**Description of choice:**

If *Disable* [0] is selected in this parameter, the [FWD/REV] key will be inactive. See parameter 200.

**017 Local reset of trip (LOCAL RESET)**

**Value:**

- Not possible (DISABLE) [0]
- ★ Possible (ENABLE) [1]

**Function:**

In this parameter, the reset function can be selected/removed from the keyboard. This key can be used when parameter 002 has been set for *Remote control* [0] or *Local control* [1].

**Description of choice:**

If *Disable* [0] is selected in this parameter, the [RESET] key will be inactive.



**NB!**

Only select *Disable* [0] if an external reset signal has been connected via the digital inputs.

**018 Lock for data change (DATA CHANGE LOCK)**

**Value:**

- ★ Not locked (NOT LOCKED) [0]
- Locked (LOCKED) [1]

**Function:**

In this parameter, the software can "lock" the control, which means that data changes cannot be made via LCP 2 (however, this is still possible via the serial communication port).

**Description of choice:**

If *Locked* [1] is selected, data changes cannot be made.

**019 Operating state at power up, local control (POWER UP ACTION)**

**Value:**

- Auto restart, use saved ref.(AUTO RESTART) [0]
- ★ Forced stop, use saved ref. (LOCAL=STOP) [1]
- Forced stop, set ref. to 0 (LOCAL=STOP, REF=0) [2]

**Function:**

Setting of the desired operating mode when the mains voltage is reconnected. This function can only be active in connection with *Local control* [1] in parameter 002.

**Description of choice:**

*Auto restart, use saved ref.* [0] is selected if the unit is to start up with the same local reference (set in parameter 003) and the same start/stop conditions (given via the [START/STOP] keys) that the VSM unit had before it was switched off.

*Forced stop, use saved ref.* [1] is used if the unit is to remain stopped when the mains voltage is connected, until the [START] key is pressed. After the start command, the local reference used is set in parameter 003.

*Forced stop, set ref. to 0* [2] is selected if the unit is to remain stopped when the mains voltage is connected. Local reference (parameter 003) is reset.



**NB!**

In remote controlled operation (parameter 002), the start/stop condition at power up will depend on the external control signals. If *Latched start* is selected in parameter 332-335, the motor will remain stopped at power up.

★ = factory setting. ( ) = display text [ ] = value for use in communication via serial communication port

**100 Configuration (CONFIG. MODE)**

**Settings:**

- ★ Speed,
  - open loop mode (SPEED OPEN LOOP) [0]
- Process,
  - closed loop mode (PROCESS CLOSED LOOP) [3]

**Function:**

This parameter is used for selecting the configuration to which the VSM unit is to be adapted.

**Description of choice:**

If *Speed, open loop mode* [0] is selected, a normal speed control (without feedback signal) is obtained, but with automatic slip compensation, ensuring a nearly constant speed at varying loads. Compensations are active, but may be disabled as required in parameter 133 - 136.

If *Process, closed loop mode* [3] is selected, the internal process regulator will be activated, thereby enabling accurate regulation of a process with respect to a given process signal. The process signal can be set using the actual process unit or as a percentage. A feedback signal must be supplied from the process, and the process setpoint must be adjusted. In process closed loop both directions is not allowed in parameter 200.

**NB!** This is only possible in Stop Mode (motor stopped on a Stop command).

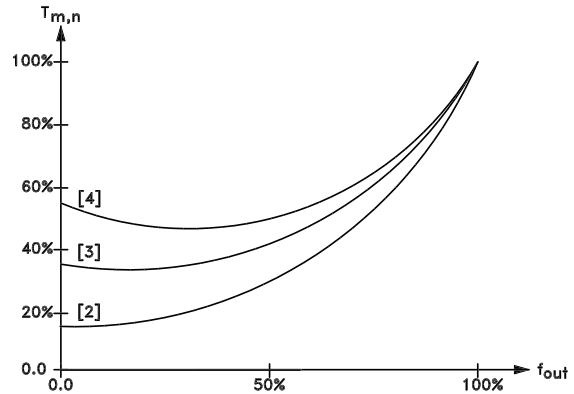

**NB!** Slip compensation (parameter 136) and start (parameter 134) are not active if a variable torque is used.

**101 Torque characteristics (TORQUE CHARACT)**

**Settings:**

- ★ Constant torque (CONSTANT TORQUE) [1]
  - Variable torque: low (VAR.TORQUE: LOW) [2]
  - Var. torque: medium (VAR.TORQUE: MEDIUM) [3]
  - Variable torque: high (VAR.TORQUE: HIGH) [4]

**Function:**

In this parameter, the principle for adjusting the U/f characteristics of the VSM unit to the torque characteristics of the load is selected.

**Description of choice:**

If *Constant torque* [1] is selected, a load-dependent U/f characteristic is obtained in which the output voltage is increased in the case of an increasing load (current) so as to maintain constant magnetisation of the motor. Select *Variable torque low* [2], *Variable torque medium* [3] or *Variable torque high* [4] if the load is square (centrifugal pumps, fans).

**102 Motor power (MOTOR POWER)**

**Value:**

XX.XX kW - depends on the VSM unit [XXXX]

**Function:**

Read only parameter.

**103 Motor voltage (MOTOR VOLTAGE)**

**Value:**

XX V- depends on the VSM unit [XX]

**Function:**

Read only parameter.

**104 Motor frequency (MOTOR FREQUENCY)**

**Value:**

XX.X Hz - depends on the VSM unit [XXX]

**Function:**

Read only parameter.

**105 Motor current (MOTOR CURRENT)**

**Value:**

XX.X X A- depends on the VSM unit [XXXX]

**Function:**

Read only parameter.

★ = factory setting. ( ) = parameter window text. [ ] = value for use in communication via serial communication port

**106 Rated motor speed  
(MOTOR NOM. SPEED)**

Value:

XX rpm - depends on the VSM unit [XX]

Function:

Read only parameter.

**126 DC braking time (DC BRAKING TIME)**

Settings:

0.0 - 60.0 sec. [0-600]

★ 10.0 sec. [100]

Function:

This parameter is for setting the DC braking time for which the DC braking voltage (parameter 132) is to be active.

0.0 sec. = OFF

Description of choice:

Set the desired time.

**127 DC brake cut-in frequency  
(DC BRAKE CUT-IN)**

Settings:

0.0 -  $f_{MAX}$  (parameter 202) [0 - ]

★ 0.0 Hz = OFF [0]

Function:

This parameter is for setting the DC brake cut-in frequency at which the DC braking voltage (parameter 132) is to be active, in connection with a Stop command.

Description of choice:

Set the desired frequency.

**128 Motor thermal protection  
(MOTOR THERM. PRO)**

Settings:

★ Disable (DISABLE) [0]

Enable (ENABLE) [1]

Function:

The motor temperature is measured with a thermistor (optional).

Description of choice:

If *Disable* [0] is selected no tripping is required when the motor is overloaded.

**132 DC braking voltage  
(DC BRAKE VOLTAGE)**

Settings:

0 - 100 % [0-100]

★ 0 % [0]

Function:

If the stator in an asynchronous motor is supplied with DC voltage, a braking torque will arise. The braking torque depends on the selected DC braking voltage. The DC braking voltage is stated as a percentage of maximum braking voltage.

Description of choice:

Set the desired voltage as a specified percentage of maximum braking voltage.



**NBI**

The DC braking voltage cannot be used as a holding brake.

**133 Start voltage (START VOLTAGE)**

Settings:

0.00 - 100.00 V [0-10000]

★ Depends on motor

Function:

You can set the motor voltage below the field weakening point independently of the motor current. Use this parameter to compensate too low starting torque.

The start voltage is the voltage at 0 Hz.



**NBI**

If the start voltage is set too high, it can lead to magnetic saturation and motor overheating; the VSM unit may trip. Therefore take care when using the start voltage.

Description of choice:

Set the desired start voltage.

★ = factory setting, ( ) = parameter window text, [ ] = value for use in communication via serial communication port

**134 Start compensation (START COMP.)**

**Settings:**

0.0 - 300.0 % [0-3000]  
 ★ 100.0 % [1000]

**Function:**

The output voltage is compensated as a function of the load.



**NB!**

If the value is too high the VSM unit can trip due to overcurrent.

**Description of choice:**

Enter a % value.  
 Rated start compensation = 100 %.

**135 U/f ratio (U/F RATIO)**

**Settings:**

0.00 - 20.00 V/Hz [0-2000]  
 ★ Motor dependent

**Function:**

The output voltage to the motor can be adjusted on a linear basis from 0 to rated frequency.

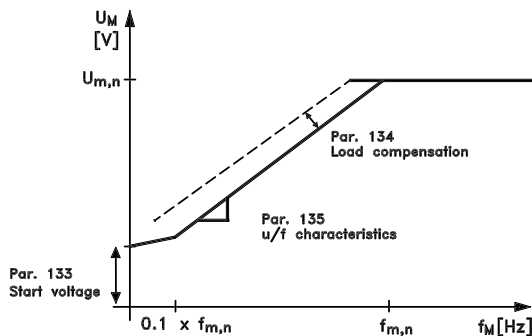

**136 Slip compensation (SLIP COMP.)**

**Settings:**

-500.0 - +500.0 % [-5000 - +5000]  
 ★ 100.0 % [1000]

**Function:**

The rated slip compensation (factory setting) is calculated on the basis of the motor parameters.

In parameter 136 the slip compensation can be adjusted in detail. Optimizing makes the motor speed less load dependent. This function is not active at the same time as variable torque (parameter 101).

**Description of choice:**

Enter a % value of rated slip compensation.

**137 DC holding voltage (DC HOLD VOLTAGE)**

**Settings:**

0 - 100 % [0-100]  
 ★ 0 (OFF) % [0]

**Function:**

This parameter is used to uphold the motor function (holding torque) or to pre-heat the motor. DC holding voltage is active at stopped motor when it is set at a value which is different from 0. Coasting stop will deactivate the function.

**Description of choice:**

Enter a percentage value.

**138 Brake cut out frequency (BRAKE CUT OUT)**

**Settings:**

0.5 - 132 Hz (parameter 200) [5-]  
 ★ 3.0 Hz [30]

**Function:**

Here the frequency at which the external brake is to be released is selected via output set in parameter 340 during running.

**Description of choice:**

Set desired frequency.

★ = factory setting. ( ) = parameter window text. [ ] = value for use in communication via serial communication port

### 139 Brake cut in frequency (BRAKE CUT IN)

#### Settings:

- 0.5 - 132 Hz (parameter 200) [5-]
- ★ 3.0 Hz [30]

#### Function:

Here the frequency at which the external brake is to be activated is selected via output set in parameter 340 when the motor is ramping down to stop.

#### Description of choice:

Set the desired frequency.

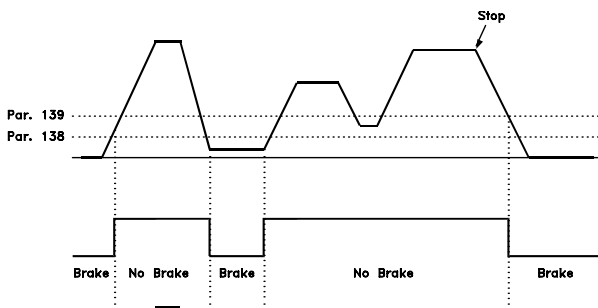

### 200 Rotation direction (ROTATION)

#### Settings:

- ★ Only clockwise, 0-132 Hz (132 Hz CLOCK WISE) [0]
- Both directions, 0-132 Hz (132 Hz BOTH DIRECTIONS) [1]
- Only counterclockwise, 0-132 Hz (132Hz COUNTERCLOCKW.) [2]

#### Function:

This parameter guarantees protection against unwanted reversing.

Using *Process, closed loop* mode (parameter 100) parameter 200 must not be changed to *Both directions* [1].

#### Description of choice:

Select the desired direction seen from the motor drive end.

Note that if *Only clockwise, 0-132 Hz* [0]/*Only counterclockwise, 0-132 Hz* [2] is selected, the output frequency will be limited to the range  $f_{MIN}$  -  $f_{MAX}$ .

★ = factory setting. ( ) = parameter window text. [ ] = value for use in communication via serial communication port

If *Both directions, 0-132 Hz* [1] is selected, the output frequency will be limited to the range  $\pm f_{MAX}$  (the minimum frequency is of no significance).



#### NB!

This is only possible in Stop Mode (motor stopped on a Stop command).

### 201 Min. output frequency (MIN OUTPUT FREQ)

#### Settings:

- 0.0 Hz -  $f_{MAX}$  (parameter 202) [0 - ]
- ★ 0.0 Hz [0]

#### Function:

In this parameter, a minimum motor frequency limit can be selected that corresponds to the minimum frequency at which the motor is to run.

The minimum frequency can never be higher than the maximum frequency,  $f_{MAX}$ .

If *Both directions* has been selected in parameter 200, the minimum frequency is of no significance.

#### Description of choice:

A value from 0.0 Hz to the max. frequency selected in parameter 202 ( $f_{MAX}$ ) can be chosen.

**202 Max. output frequency  
(MAX OUTPUT FREQ)**

Settings:

$f_{MIN}$  (parameter 201) -  $f_{RANGE}$  (132 Hz, par. 200)

★  $f_{RANGE}$

Function:

In this parameter, a maximum motor frequency can be selected that corresponds to the highest frequency at which the motor is to run.

See also parameter 205.

Description of choice:

A value from  $f_{MIN}$  to 132 Hz can be selected.

**203 Reference/feedback range  
(REF/FEEDB. RANGE)**

Settings:

★ Min - Max (MIN - MAX) [0]

- Max - + Max (-MAX-+MAX) [1]

Function:

This parameter decides whether the reference signal is to be positive or can be both positive and negative.



Analogue input (reference/feedback) can only be positive.

Choose *Min - Max* [0] if *Process, closed loop mode* has been selected in parameter 100.

Description of choice:

Choose the desired range.

**204 Minimum reference  
(MIN. REFERENCE)**

Settings:

-100,000.000 - Ref<sub>MAX</sub> (par. 205) [-100000000 - ]

★ 0.000 [0]

Depends on parameter 100.

Function:

The *Minimum reference* gives the minimum setting that can be assumed by the sum of all references.

*Minimum reference* is only active if *Min - Max* [0] has been set in parameter 203; however, it is always active in *Process, closed loop mode* (parameter 100).

Description of choice:

Is only active when parameter 203 has been set to *Min - Max* [0].

Set the desired value.

**205 Maximum reference  
(MAX. REFERENCE)**

Settings:

Ref<sub>MIN</sub> (parameter 204)-100,000,000 [-100000000]

★ 50.000 [50000]

Function:

The *Maximum reference* gives the highest value that can be assumed by the sum of all references.

If parameter 100 has been selected to open loop the max. setting is 132 Hz.

If closed loop has been selected the maximum reference cannot be set higher than the maximum feedback (parameter 415).

Description of choice:

Set the desired value.

★ = factory setting. ( ) = parameter window text. [ ] = value for use in communication via serial communication port

**207 Ramp-up time (RAMP UP TIME )**

Settings:

0.15 - 3600.00 sec. [5 - 360000]

★ 3.00 sec. [300]

Function:

The ramp-up time is the acceleration time from 0 Hz to the rated motor frequency  $f_{M,N}$  (parameter 104). This presupposes that the current limit is not reached (to be set in parameter 221).

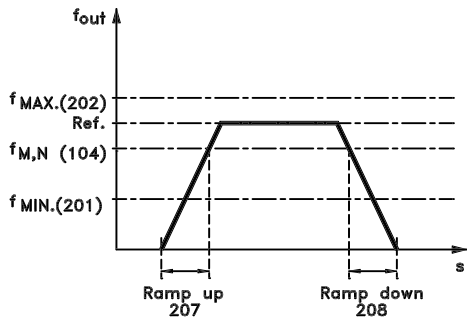

Description of choice:

Program the desired ramp-up time.

**208 Ramp-down time (RAMP DOWN TIME )**

Settings:

0.15 - 3600.00 sec. [5 - 360000]

★ 3.00 sec. [300]

Function:

The ramp-down time is the deceleration time from the rated motor frequency  $f_{M,N}$  (parameter 104) to 0 Hz provided there is no over-voltage in the inverter because of regenerative operation of the motor, and the current limit is not reached (to be set in parameter 221).

Description of choice:

Program the desired ramp-down time.

**211 Jog ramp time (JOG RAMP TIME)**

Settings:

0.15 - 3600.00 sec. [5 - 360000]

★ 3.00 sec. [300]

Function:

The jog ramp time is the acceleration/deceleration time from 0 Hz to the rated motor frequency  $f_{M,N}$  (parameter 104), provided there is no over-voltage in the inverter because of regenerative operation of the motor, and the current limit is not reached (to be set in parameter 221).

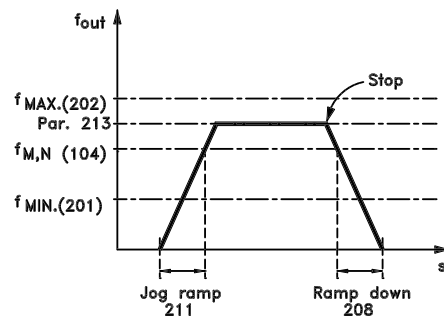

The jog ramp time starts if a jog signal is given via the digital inputs or the serial communication port.

Description of choice:

Set the desired ramp time.

**212 Quick stop ramp-down time (Q STOP RAMP TIME)**

Settings:

0.15 - 3600.00 sec. [5 - 360000]

★ 3.00 sec. [300]

Function:

The ramp-down time is the deceleration time from the rated motor frequency to 0 Hz, provided there is no over-voltage in the inverter because of regenerative operation of the motor, and the current limit is not reached (to be set in parameter 221).

Quick-stop is activated by means of a signal on one of the digital input terminals (2-5), or via the serial communication port.

Description of choice:

Program the desired ramp-down time.

★ = factory setting. ( ) = parameter window text. [ ] = value for use in communication via serial communication port

**213 Jog frequency (JOG FREQUENCY)**

Settings:

0.0 Hz - parameter 202 [0 - ]  
 ★ 10.0 Hz [100]

Function:

The jog frequency  $f_{JOG}$  is the fixed output frequency at which the VSM unit is running when the jog function is activated.

Description of choice:

Set the desired frequency.

**214 Reference function (REF FUNCTION)**

Settings:

★ Sum (SUM) [0]  
 External/preset (EXTERNAL/PRESET) [2]

Function:

It is possible to define how the preset references are to be added to the other references. For this purpose, *Sum* is used. It is also possible - by using the *External/preset* function - to select whether a shift between external references and preset references is desired.

Description of choice:

If *Sum* [0] is selected, one of the adjusted preset references (parameters 215-216) is added as a percentage of the maximum possible reference.

If *External/preset* [2] is selected, it is possible to shift between external references or preset references via terminal 2, 3, 4, or 5 (parameter 332, 333, 334, or 335). Preset references will be a percentage value of the reference range.

External reference is the sum of the analogue references, pulses and bus references.



**NB!**  
 If *Sum* is selected, one of the preset references will always be active. If the preset references are to be without influence, they should be set to 0 % (as in the factory setting).

**215 Preset reference 1 (PRESET REF. 1)**

**216 Preset reference 2 (PRESET REF. 2)**

Settings:

-100.00 % - +100.00 % [-10000 - +10000]  
 % of the reference range/external reference  
 ★ 0.00% [0]

Function:

Two different preset references can be programmed in parameters 215-216.

The preset reference is stated as a percentage of the value  $Ref_{MAX}$  or as a percentage of the other external references, depending on the choice made in parameter 214. If a  $Ref_{MIN} \neq 0$  has been programmed, the preset reference as a percentage will be calculated on the basis of the difference between  $Ref_{MAX}$  and  $Ref_{MIN}$ , following which the value is added to  $Ref_{MIN}$ .

Description of choice:

Set the fixed reference(s) that is/are to be the options.

To use the fixed references, it is necessary to have selected Preset ref. enable on terminal 2, 3, 4, or 5 (parameters 332 - 335).

Choices between fixed references can be made by activating terminal 2, 3, 4, or 5 - see the table below.

Terminals 2/3/4/5

Preset reference

Preset reference 1	0
Preset reference 2	1

**219 Catch up/slow down value (CATCH UP/SLW DWN)**

Settings:

0.00 - 100.00 % [0 - 10000]  
 ★ 0.00 % [0]

Function:

This parameter enables the entry of a percentage value (relative) which will either be added to or deducted from the actual reference.

Description of choice:

If *Catch up* has been selected via one of the terminals 2, 3, 4, or 5 (parameters 332 - 335), the percentage (relative) value selected in parameter 219 will be added to the total reference.

★ = factory setting. ( ) = parameter window text. [ ] = value for use in communication via serial communication port

If *Slow down* has been selected via one of the terminals 2, 3, 4, or 5 (parameters 332 - 335), the percentage (relative) value selected in parameter 219 will be deducted from the total reference.

**221 Current limit for motor mode (CURRENT LIMIT)**

**Settings:**

Min. limit (XX.X) - max. limit (XXX.X) [XXX - XXXX]  
in % of  $I_{RATED}$   
★ Max. limit (XXX.X) [XXXX]

$I_{RATED}$  = rated motor current  
Min. limit = magnetising current in % of  $I_{RATED}$   
Max. limit = unit dependent limit in % of  $I_{RATED}$

**Function:**

This function is relevant for all application configurations; speed and process regulation. This is where to set the current limit for motor operation.

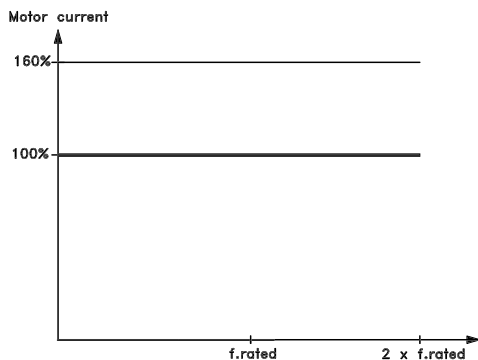
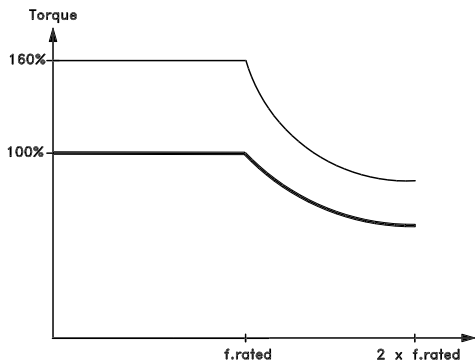

**Description of choice:**

Set the desired % of current.



**NBI**

For 2 pole motors (0.75 - 1.1 kW), the setting is limited to 120% which corresponds to 160% torque, setting 85% corresponds to 100% torque.

**229 Frequency bypass, bandwidth (FREQ BYPASS B.W.)**

**Settings:**

0 (OFF) - 100% [0-100]  
★ 0 (OFF) % [0]

**Function:**

Some systems call for some output frequencies to be avoided because of resonance problems in the system.

In parameters 230-231 these output frequencies can be programmed for bypassing (Frequency bypass). In this parameter (229), a bandwidth can be defined on either side of these frequency bypasses.

**Description of choice:**

The bypass band is the bypass frequency +/- half the set bandwidth.

A percentage of the setting in parameters 230-231 is selected.

**230 Frequency bypass 1 (FREQ. BYPASS 1)**

**231 Frequency bypass 2 (FREQ. BYPASS 2)**

**Settings:**

0.0 - 132 Hz (parameter 200) [0 - ]  
★ 0.0 Hz [0]

**Function:**

Some systems call for some output frequencies to be avoided because of resonance problems in the system.

**Description of choice:**

Enter the frequencies to be avoided.

See also parameter 229.

★ = factory setting. ( ) = parameter window text. [ ] = value for use in communication via serial communication port

**317 Time out  
(LIVE ZERO TIME O)**

Settings:  
1 - 99 sec. [1 - 99]  
★ 10 sec. [10]

Function:

If the value of the reference signal connected to the input, terminal 1, falls below 50% of the setting in parameter 336 for a period longer than the time set in parameter 317, the function selected in parameter 318 will be activated.

Description of choice:

Set the desired time.

**318 Function after time out  
(LIVE ZERO FUNCT.)**

Settings:  
★ Off (OFF) [0]  
Stop and trip (STOP AND TRIP) [5]

Function:

This parameter allows a choice of the function to be activated if the value of the reference signal connected to the input, terminal 1, falls below 50% of the setting in parameter 336 for a period longer than the time set in parameter 317.

If a time-out function (parameter 318) occurs at the same time as a bus time-out function (parameter 514), the time-out function (parameter 318) will be activated.

**327 Pulse reference/feedback, max. frequency  
(PULSE REF/FB MAX)**

Settings:  
100 - 70000 Hz [100 - 70000]  
★ 5000 Hz [5000]

Function:

In this parameter, the signal value is set that corresponds to the maximum reference/feedback value set in parameter 205/415.

Description of choice:

Set the desired pulse frequency.



**NB!**

Frequency limit:  
Open collector 24 V: 8 kHz  
Push pull 24 V: 70 kHz

**331 Terminal 1, analogue input current  
(AI [mA] 1 FUNCT)**

Settings:  
★ No operation (NO OPERATION) [0]  
Reference (REFERENCE) [1]  
Feedback (FEEDBACK) [2]

Function:

This parameter allows a choice between the different functions available for the input, terminal 1.

Scaling of the input signal is effected in parameters 338 and 339.

Description of choice:

*No operation.* Is selected if the VSM unit is not to react to signals connected to the terminal.

*Reference.* Is selected to enable change of reference by means of an analogue reference signal.

If other inputs are connected, these are added up, taking account of their signs.

*Feedback.* Is selected if closed loop regulation with an analogue signal is used.



**NB!**

If *Reference* or *Feedback* has been selected on more than one terminal, these signals will be added.

★ = factory setting. ( ) = parameter window text. [ ] = value for use in communication via serial communication port

<b>332 Terminal 2, analogue/digital input</b>
<b>(DIGITAL INPUT 2)</b>
<b>333 Terminal 3, digital input</b>
<b>(DIGITAL INPUT 3)</b>
<b>334 Terminal 4, digital input</b>
<b>(DIGITAL INPUT 4)</b>
<b>335 Terminal 5, digital input</b>
<b>(DIGITAL INPUT 5)</b>

**Function:**

In parameters 332-335 it is possible to choose between the different possible functions related to the inputs on terminals 2-5. The function options are shown in the table below.

Parameter		332	333	334	335
Digital input on terminal no.		2	3	4	5
<b>Settings:</b>					
No function	(NO OPERATION)	[0]	[0]	[0]	[0]
Reset	(RESET)	[1]	★ [1]	[1]	[1]
Coasting stop, inverse	(MOTOR COAST INVERSE)	[2]	[2]	[2]	[2]
Reset and coasting stop, inverse	(RESET & COAST INV.)	[3]	[3]	[3]	[3]
Quick-stop, inverse	(QUICK STOP INVERSE)	[4]	[4]	[4]	[4]
DC-braking, inverse	(DC-BRAKE INVERSE)	[5]	[5]	[5]	[5]
Stop inverse	(STOP INVERSE)	[6]	[6]	[6]	[6]
Start	(START)	[7]	[7]	★ [7]	[7]
Latched start	(LATCHED START)	[8]	[8]	[8]	[8]
Reversing	(REVERSING)	[9]	[9]	[9]	[9]
Start reversing	(START REVERSING)	[10]	[10]	[10]	[10]
Start clockwise, on	(ENABLE FORWARD)	[11]	[11]	[11]	[11]
Start counter-clockwise, on	(ENABLE REVERSE)	[12]	[12]	[12]	[12]
Jog	(JOGGING)	[13]	[13]	[13]	★ [13]
Freeze reference	(FREEZE REFERENCE)	[14]	[14]	[14]	[14]
Freeze output	(FREEZE OUTPUT)	[15]	[15]	[15]	[15]
Speed up	(SPEED UP)	[16]	[16]	[16]	[16]
Speed down	(SPEED DOWN)	[17]	[17]	[17]	[17]
Selection of Setup	(SETUP SELECT)	[18]	[18]	[18]	[18]
Catch-up	(CATCH UP)	[19]	[19]	[19]	[19]
Slow-down	(SLOW DOWN)	[20]	[20]	[20]	[20]
Preset reference	(PRESET REF.)	[21]	[21]	[21]	[21]
Preset reference, on	(PRESET REF. ON)	[22]	[22]	[22]	[22]
Precise stop, inverse	(PRECISE STOP)			[23]	
Pulse reference	(PULSE REFERENCE)		[24]		
Pulse feedback	(PULSE FEEDBACK)		[25]		
Analogue reference	(REFERENCE)	★ [30]			
Analogue feedback	(FEEDBACK)	[31]			
Reset and start	(RESET AND START)	[32]	[32]	[32]	[32]

**Description of choice:**

**No function** is selected if the VSM unit is not to react to signals transmitted to the terminal.

**Reset** zeroes the VSM unit after an alarm; however, not all alarms can be reset without disconnecting from mains.

**Coasting stop, inverse** is used for making the VSM unit run freely to stop. Logic '0' leads to coasting stop.

**Reset and coasting stop, inverse**, is used for activating coasting stop at the same time as reset.

Logic '0' leads to coasting stop and reset.

**Quick-stop, inverse** is used for stopping the motor in accordance with the quick-stop ramp (set in parameter 212).

Logic '0' leads to a quick-stop.

★ = factory setting. ( ) = parameter window text. [ ] = value for use in communication via serial communication port

**DC braking, inverse** is used for stopping the motor by energizing it with a DC voltage for a given time, see parameters 126-127.

Please note that this function is only active if the settings of parameters 126-127 is different from 0. Logic '0' leads to DC braking.

**Stop inverse** is activated by interrupting the voltage to the terminal. This means that if the terminal has no voltage, the motor cannot run. The stop will be effected in accordance with the selected ramp (parameters 207/208).



None of the above-mentioned stop commands are to be used as disconnection switch in connection with repairs. Cut mains instead.

**Start**, is selected if a start/stop command is desired. Logic '1' = start, logic '0' = stop (stand-by).

**Latched start** - if a pulse is applied for min. 20 ms, the motor will start, provided no stop command. The motor stops if Stop inverse is activated briefly.

**Reversing** is used for changing the direction of rotation of the motor shaft. Logic "0" will not lead to reversing. Logic "1" will lead to reversing. The reversing signal only changes the direction of rotation; it does not activate the start function.

Should not be used with *Process, closed loop mode*.

**Start reversing**, is used for start/stop and for reversing with the same signal. No start signal is allowed at the same time. Acts as latch start reversing, provided latch start has been chosen for another terminal.

Should not be used with *Process, closed loop mode*.

**Start clockwise, on** is used if the motor shaft is only to be able to rotate clockwise when starting.

Should not be used with *Process, closed loop mode*.

**Start counter-clockwise, on** is used if the motor shaft is to be able to rotate counter-clockwise when started.

Should not be used with *Process, closed loop mode*.

**Jog** is used for overriding the output frequency to the jog frequency set in parameter 213. The ramp time can be set in parameter 211. Jog is not active if a stop command has been given (start-disable).

Jog overrides stand-by.

**Freeze reference** - freezes the actual reference. The frozen reference is now the point of enable/condition for *Speed up* and *Speed down* to be used.

If speed up/down is used, the speed change always follows the normal ramp (parameters 207/208) in the range 0 - Ref<sub>MAX</sub>.

**Freeze output** - freezes the actual motor frequency (Hz). The frozen motor frequency is now the point of enable/condition for *Speed up* and *Speed down* to be used.

Freeze output overrides start/stand-by, slip compensation and closed loop process control.

If speed up/down is used, the speed change always follows the normal ramp (parameters 207/208) in the range 0 - f<sub>M,N</sub>.

**Speed up and Speed down** are selected if digital control of the up/down speed is desired (motor potentiometer). This function is only active if *Freeze reference* or *Freeze output* has been selected.

As long as there is a logic '1' on the terminal selected for speed up, the reference or the output frequency will increase.

As long as there is a logic '1' on the terminal selected for speed down, the reference or the output frequency will be reduced.

Pulses (logic '1' minimum high for 20 ms and a minimum pause of 20 ms) will lead to a change of speed of 0.1% (reference) or 0.1 Hz (output frequency).

Example:

	Terminal	Terminal	Freeze ref./
	2-5	2-5	Freeze output
No speed change	0	0	1
Speed down	0	1	1
Speed up	1	0	1
Speed down	1	1	1

★ = factory setting. ( ) = parameter window text. [ ] = value for use in communication via serial communication port

**Selection of Setup**, enables a choice of one of the two Setups; however, this presupposes that parameter 004 has been set to *Multi Setup*.

**Catch-up/Slow-down** is selected if the reference value is to be increased or reduced by a programmable percentage value set in parameter 219.

	Slow-down	Catch-up
Unchanged speed	0	0
Reduced by %-value	1	0
Increased by %-value	0	1
Reduced by %-value	1	1

**Preset reference** enables a choice of one of the two preset references, in accordance with the table in parameter 215 and 216. To be active, *Preset reference, on* has to be selected.

**Preset reference, on** is used for shifting between external reference and preset reference. It is assumed that *External/preset* [2] has been selected in parameter 214. Logic '0' = external references active; logic '1' = one of the two preset references is active.

**Precise stop** corrects the ramp-down time to obtain a high repetitive accuracy of the stopping point.

**Pulse reference** is selected if a pulse sequence (frequency) of 0 Hz is used, corresponding to Ref<sub>MIN</sub>, parameter 204. The frequency is set in parameter 327, corresponding to Ref<sub>MAX</sub>.

**Pulse feedback** is selected if a pulse sequence (frequency) is selected as a feedback signal. See also page 50.

**Analogue reference** is selected to enable change of reference by means of an analogue reference signal. See also page 50.

If other inputs are connected, these are added up, taking account of their signs.

**Analogue feedback** is selected if closed loop regulation with an analogue signal is used.

**Reset and start** is used for activating start at the same time as reset.

Scaling of the input signal is effected in parameters 338 and 339.



**NB!**

If *Reference* or *Feedback* has been selected on more than one terminal, these signals will be added with signs.

**336 Terminal 1, min. scaling (AI 1 SCALE LOW)**

**Settings:**

0.0 - 20.0 mA [0 - 200]  
 ★ 0.0 mA [0]

**Function:**

This parameter determines the value of the reference signal that is to correspond to the minimum reference value set in parameter 204.

If the *Time-out* function of parameter 317 is to be used, the setting must be > 2 mA.

**Description of choice:**

Set the desired current value.

**337 Terminal 1, max. scaling (AI 1 SCALE HIGH)**

**Setting:**

0.0 - 20.0 mA [0 - 200]  
 ★ 20.0 mA [200]

**Function:**

This parameter sets the value of the reference signal that is to correspond to the maximum reference value set in parameter 205.

**Description of choice:**

Set the desired current value.

**338 Terminal 2, min. scaling (AI 2 SCALE LOW)**

**Settings:**

0.0 - 10.0 V [0 - 100]  
 ★ 0.0 V [0]

**Function:**

This parameter is used for setting the signal value that corresponds to the minimum reference value set in parameter 204.

**Description of choice:**

Set the desired voltage value.

★ = factory setting. ( ) = parameter window text. [ ] = value for use in communication via serial communication port

**339 Terminal 2, max. scaling (AI 2 SCALE HIGH)**

Settings:

0.0 - 10.0 V	[0 - 100]
★ 10.0 V	[100]

**Function:**

This parameter is used for setting the signal value that corresponds to the maximum reference value set in parameter 205.

**Description of choice:**

Set the desired voltage value.

**340 Terminal 9, output functions (OUTPUT FUNC.)**

Settings:

★ No function	(NO OPERATION)	[0]
Ready signal	(UNIT READY)	[1]
Enable, no warning	(ENABLE/NO WARNING)	[2]
Running	(MOTOR RUNNING)	[3]
Running, no warning	(RUNNING NO WARNING)	[4]
Running on reference, no warning	(RUNNING ON REFERENCE)	[5]
Fault	(FAULT)	[6]
Fault or warning	(FAULT OR WARNING)	[7]
Current limit	(CURRENT LIMIT)	[8]
Thermal warning	(THERMAL WARNING)	[9]
Reversing	(REVERSE)	[10]
Off 123	(OFF 123 RELAY)	[11]
Actual frequency 0-20 mA	(0-FMAX = 0-20 mA)	[12]
Actual frequency 4-20 mA	(0-FMAX = 4-20 mA)	[13]
Reference <sub>MIN</sub> - reference <sub>MAX</sub> : 0-20 mA	(REF MIN-MAX =0-20 mA)	[14]
Reference <sub>MIN</sub> - reference <sub>MAX</sub> : 4-20 mA	(REF MIN-MAX =4-20 mA)	[15]
Feedback <sub>MIN</sub> - feedback <sub>MAX</sub> : 0-20 mA	(FB MIN-MAX =0-20 mA)	[16]
Feedback <sub>MIN</sub> - feedback <sub>MAX</sub> : 4-20 mA	(FB MIN-MAX =4-20 mA)	[17]
Actual current 0-20 mA	(0-IMAX = 0-20 mA)	[18]
Actual current 4-20 mA	(0-IMAX = 4-20 mA)	[19]
Mechanical brake	(MECHANICAL BRAKE)	[20]

**Function:**

This output can act both as a digital and an analogue output. If used as a digital output (data value [0]-[20]), a 24 V DC signal is transmitted; if used as an analogue output either a 0-20 mA signal, or a 4-20 mA signal output.

*Running on reference, no warning*, speed according to reference. No warning.

*Fault*, output is activated by alarm.

*Fault or warning*, the output is activated by alarm or warning.

**Description of choice:**

*Unit Ready signal*, the VSM unit is ready for use.

*Current limit*, the current limit in parameter 221 has been exceeded.

*Enable/no warning*, the VSM unit is ready for use; no start or stop command has been given (start/disable). No warning.

*Thermal warning*, above the temperature limit in the frequency converter.

*Motor Running*, the output frequency is higher than 0.1 Hz. A start command has been given.

*Reverse*. Logic '1' = relay activated, 24 V DC on the output when the direction of rotation of the motor is clockwise. Logic '0' = relay not activated, no signal on the output, when the direction of rotation of the motor is counter-clockwise.

*Running no warning*, the output frequency is higher than 0.1 Hz. A start command has been given. No warning.

★ = factory setting. ( ) = parameter window text. [ ] = value for use in communication via serial communication port

---

## VSM

---

*Off 123 relay*, if Profidrive [0] has been selected in parameter 512, the output is activated. If either OFF1, OFF2 or OFF3 (bit in the control word) is logic '1'.

$0-f_{MAX}$  (parameter 202)  $\Rightarrow$  0-20 mA and  
 $0-f_{MAX}$  (parameter 202)  $\Rightarrow$  4-20 mA

$Reference_{MIN}$  -  $Reference_{MAX}$ : 0-20 mA and  
 $Reference_{MIN}$  -  $Reference_{MAX}$ : 4-20 mA

$Feedback_{LOW}$  -  $Feedback_{HIGH}$ : 0-20 mA and  
 $Feedback_{LOW}$  -  $Feedback_{HIGH}$ : 4-20 mA

$0-I_{VLT, MAX}$   $\Rightarrow$  0-20 mA and  
 $0-I_{VLT, MAX}$   $\Rightarrow$  4-20 mA

*Mechanical brake*, enables control of an optional external mechanical brake (see also parameter 138 and 139).

**400 Brake functions (BRAKE FUNCTIONS)**

Settings:

- ★ OFF (OFF) [0]
- AC brake (AC BRAKE) [4]

Function:

AC brake [4] can be selected to improve braking.

Description of choice:

Select AC brake [4] if short-term generated loads occur.

**405 Reset function (RESET MODE)**

Settings:

- ★ Manual reset (MANUAL RESET) [0]
- Automatic reset x 1 (AUTOMATIC X 1) [1]
- Automatic reset x 2 (AUTOMATIC X 2) [2]
- Automatic reset x 3 (AUTOMATIC X 3) [3]
- Automatic reset x 4 (AUTOMATIC X 4) [4]
- Automatic reset x 5 (AUTOMATIC X 5) [5]
- Automatic reset x 6 (AUTOMATIC X 6) [6]
- Automatic reset x 7 (AUTOMATIC X 7) [7]
- Automatic reset x 8 (AUTOMATIC X 8) [8]
- Automatic reset x 9 (AUTOMATIC X 9) [9]
- Automatic reset x 10 (AUTOMATIC X 10) [10]
- Reset at power-up (RESET AT POWER UP) [11]

Function:

This parameter makes it possible to select the reset function desired after tripping.

After reset, the VSM unit can be restarted after 1.5 sec.

Description of choice:

If *Manual reset* [0] is selected, reset must be effected via the digital inputs.

If the VSM unit is to carry out an automatic reset (max. 1-10 times within 10 minutes) after tripping, select data value [1]-[10].



Warning: The motor may start without warning up to 10 x 5 sec. after trip.

**411 Switching frequency (SWITCH FREQ.)**

Settings:

- 1.5 -14.0 kHz [1500 - 14000]
- ★ Unit dependent

Function:

The setting determines the switching frequency of the inverter. If the switching frequency is changed, this may help to minimise possible acoustic noise from the motor.

Description of choice:

When the motor is running, the switching frequency is adjusted in parameter 411 until the frequency has been obtained at which the motor is as low-noise as possible.

See also parameter 446 - switching pattern. See derating in chapter 10.



**NB!**

Switching frequencies higher than 4 kHz may cause thermal trip depending on ambient temperature.

**412 Variable switching frequency (VAR CARRIER FREQ)**

Settings:

- Not possible (DISABLE) [0]
- Variable switching freq. (VAR. CARRIER FREQ.) [1]
- ★ Temperature dep. sw. freq. (TEMP. DEP. FREQ.) [2]

Function:

This function makes it possible to change the switching frequency depending on the load. However, the maximum switching frequency is determined by the value set in parameter 411.

Description of choice:

Select *Not possible* [0] if a permanent switching frequency is desired. Set the switching frequency in parameter 411.

If *Variable switching frequency* [1] is selected the switching frequency will decline at an increasing output frequency. This is used in applications with square torque characteristics (centrifugal pumps and fans) in which the load declines depending on the output frequency.

If *Temperature dependent switching frequency* [2] is selected, the switching frequency will decline at an increasing inverter temperature, see the drawing below.

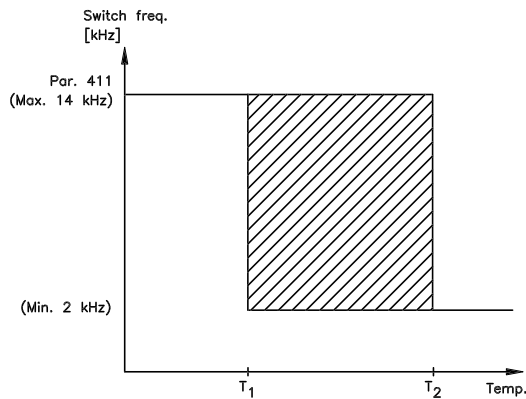

**413 Overmodulation function (OVERMODULATION)**

**Settings:**  
Off (OFF) [0]  
★ On (ON) [1]

**Function:**  
This parameter allows connection of the overmodulation function for the output voltage.

**Description of choice:**  
*Off* means that there is no overmodulation of the output voltage, which means that torque ripple on the motor shaft is avoided. This can be a good feature, e.g. on grinding machines.

*On* means that an output voltage can be obtained which is greater than the mains voltage (up to 5%).

**414 Minimum feedback (MIN. FEEDBACK)**

**Settings:**  
-100,000,000 - FB<sub>HIGH</sub> (par. 415) [-100000000 - ]  
★ 0.000 [0]

**Function:**  
Parameters 414 and 415 are used to scale the feedback range to physical values used by the user. The setting will also be the bounds of the reference (parameters 204 and 205).

Used together with *Process, closed loop mode* (parameter 100).

**Description of choice:**  
Is only active when parameter 203 has been set to *Min-Max* [0].

**415 Maximum feedback (MAX. FEEDBACK)**

**Settings:**  
(par. 414) FB<sub>LOW</sub> - 100,000,000 [- 100000000]  
★ 1.500.000 [1500000]

**Function:**  
See description of parameter 414.

**416 Reference/feedback unit (REF/FEEDB. UNIT)**

**Settings:**

NO UNIT	[0]	t/min	[21]
★ %	[1]	t/h	[22]
PPM	[2]	m	[23]
RPM	[3]	Nm	[24]
bar	[4]	m/s	[25]
CYCLE/min	[5]	m/min	[26]
PULSE/s	[6]	°F	[27]
UNITS/s	[7]	in wg	[28]
UNITS/min	[8]	gal/s	[29]
UNITS/h	[9]	ft <sup>3</sup> /s	[30]
°C	[10]	gal/min	[31]
Pa	[11]	ft <sup>3</sup> /min	[32]
l/s	[12]	gal/h	[33]
m <sup>3</sup> /s	[13]	ft <sup>3</sup> /h	[34]
l/min	[14]	lb/s	[35]
m <sup>3</sup> /min	[15]	lb/min	[36]
l/h	[16]	lb/h	[37]
m <sup>3</sup> /h	[17]	lb ft	[38]
kg/s	[18]	ft/s	[39]
kg/min	[19]	ft/min	[40]
kg/h	[20]	Hz	[41]

**Function:**  
Choose among different units to be shown on the display.  
This unit is also used directly in *Process regulation, closed loop* as a unit for *Minimum/Maximum reference* (parameters 204/205) and *Minimum/Maximum feedback* (parameters 414/415).  
The possibility of choosing a unit in parameter 416 will depend on the choices made in the following parameters:  
Par. 002 *Local/remote control*.  
Par. 013 *Local control/config. as par. 100*.  
Par. 100 *Configuration*.

★ = factory setting. ( ) = parameter window text. [ ] = value for use in communication via serial communication port

Select parameter 002 as *Remote control*

If parameter 100 is selected as *Speed regulation, open loop*, the unit selected in parameter 416 can be used in displays (par. 009-12 *Feedback [unit]*) of process parameters.

Note: The reference can only be shown in Hz (*Speed regulation, open loop*).

If parameter 100 is selected as *Process regulation, closed loop*, the unit selected in parameter 416 will be used when displaying both reference (par. 009-12: *Reference [unit]*) and feedback (par. 009-12: *Feedback [unit]*).

Select parameter 002 as *Local control*

If parameter 013 is chosen as *LCP control and open loop* or *LCP digital control and open loop*, the reference will be given in Hz, regardless of the choice made in parameter 416. If parameter 013 is chosen as *LCP control/as par. 100* or *LCP digital control/as par. 100*, the unit will be as described above under parameter 002, Remote-control.



**NB!**

The above applies to display of *Reference [unit]* and *Feedback [unit]*. If *Reference [%]* or *Feedback [%]* is selected, the value displayed will be in the form of a percentage of the selected range.

**Description of choice:**

Select the desired unit for the reference/feedback signal.

**437 Process PID Normal/inverse control (PROC NO/INV CTRL)**

**Settings:**

- ★ Normal (NORMAL) [0]
- Inverse (INVERSE) [1]

**Function:**

It is possible to choose whether the process regulator is to increase/reduce the output frequency if there is a difference between the reference signal and the feedback signal.

Used together with *Process, closed loop mode* (parameter 100).

**Description of choice:**

If the VSM unit is to reduce the output frequency in case the feedback signal increases, select *Normal* [0].

If the VSM unit is to increase the output frequency in case the feedback signal increases, select *Inverse* [1].

★ = factory setting. ( ) = parameter window text. [ ] = value for use in communication via serial communication port

**438 Process PID anti windup (PROC ANTI WINDUP)**

**Settings:**

- Disable (DISABLE) [0]
- ★ Enable (ENABLE) [1]

**Function:**

It is possible to select whether the process regulator is to continue regulating on an error even if it is not possible to increase/reduce the output frequency. Used together with *Process, closed loop mode* (parameter 100).

**Description of choice:**

The factory setting is *Enable* [1], which means that the integration link is adjusted in relation to the actual output frequency if either the current limit or the max./min. frequency has been reached. The process regulator will not engage again until either the error is zero or its sign has changed.

Select *Disable* [0] if the integrator is to continue integrating on an error, even if it is not possible to remove the fault by such regulation.



**NB!**

If *Disable* [0] is selected, it will mean that when the error changes its sign, the integrator will first have to integrate down from the level obtained as a result of the former error, before any change to the output frequency occurs.

**439 Process PID start frequency (PROC START VALUE)**

**Settings:**

- $f_{MIN}-f_{MAX}$  (parameter 201 and 202) X.X
- ★ parameter 201

**Function:**

When the start signal comes, the VSM unit will react in the form of *Speed, open loop mode* following the ramp. Only when the programmed start frequency has been obtained, will it change over to *Process, closed loop mode*. In addition, it is possible to set a frequency that corresponds to the speed at which the process normally runs, which will enable the required process conditions to be reached sooner.

Used together with *Process, closed loop mode* (parameter 100).

**Description of choice:**

Set the required start frequency.



**NB!**

If the VSM unit is running at the current limit before the desired start frequency is obtained, the process regulator will not be activated. For the regulator to be activated anyway, the start frequency must be lowered to the required output frequency. This can be done during operation.

**440 Process PID proportional gain (PROC. PROP. GAIN)**

**Settings:**

0.00 (OFF) - 10.00 [0 - 1000]  
 ★ 0.01 [1]

**Function:**

The proportional gain indicates the number of times the error between the set point and the feedback signal is to be applied.

Used together with *Process, closed loop mode* (parameter 100).

**Description of choice:**

Quick regulation is obtained by a high gain, but if the gain is too high, the process may become unstable.

**441 Process PID integral time (PROC. INTEGR. T.)**

**Settings:**

0.01 - 9999 sec. (OFF) [1 - 999900]  
 ★ 9999 sec. [999900]

**Function:**

The integrator provides an increasing gain at a constant error between the set point and the feedback signal. The greater the error, the quicker the gain will increase. The integral time is the time needed by the integrator to reach the same gain as the proportional gain.

Used together with *Process, closed loop mode* (parameter 100).

**Description of choice:**

Quick regulation is obtained at a short integral time. However, this time may become too short, which can make the process unstable.

If the integral time is long, major deviations from the required set point may occur, since the process regulator will take a long time to regulate in relation to a given error.

**442 Process PID differentiation time (PROC. DIFF. TIME)**

**Settings:**

0.00 (OFF) - 10.00 sec. [0 - 1000]  
 ★ 0.00 sec. [0]

**Function:**

The differentiator does not react to a constant error. It only provides a gain when the error changes. The quicker the error changes, the stronger the gain from the differentiator.

The gain is proportional to the speed at which the error changes.

Used together with *Process, closed loop mode* (parameter 100).

**Description of choice:**

Fast regulation is obtained with a long differentiation time. However, this time may become too long, which can make the process unstable.

**443 Process PID diff. gain limit (PROC. DIFF. GAIN)**

**Settings:**

5.0 - 50.0 [50 - 500]  
 ★ 5.0 [50]

**Function:**

It is possible to set a limit for the differentiator gain.

The differentiator gain will increase if there are fast changes, which is why it can be beneficial to limit this gain, thereby obtaining a pure differentiator gain at slow changes and a constant differentiator gain where quick changes to the error occur.

Used together with *Process, closed loop mode* (parameter 100).

★ = factory setting. ( ) = parameter window text. [ ] = value for use in communication via serial communication port

**Description of choice:**

Select a limit to differentiator gain as required.

**444 Process PID lowpass filter time  
(PROC. FILTER TIME)**

**Settings:**

0.01 - 10.00 sec [1 - 1000]  
★ 0.01 sec [1]

**Function:**

Oscillations on the feedback signal are dampened by the lowpass filter in order to reduce their impact on the process regulation. This can be an advantage e.g. if there is a lot of noise on the signal.

Used together with *Process, closed loop mode* (parameter 100).

**Description of choice:**

Select the desired time constant ( $\tau$ ). If a time constant ( $\tau$ ) of 100 ms is programmed, the break frequency for the lowpass filter will be  $1/0.1 = 10 \text{ RAD/sec.}$ , corresponding to  $(10/2 \times \pi) = 1.6 \text{ Hz.}$

The process regulator will thus only regulate a feedback signal that varies by a frequency lower than 1.6 Hz. If the feedback signal varies by a higher frequency than 1.6 Hz, the Process regulator will not react.

**445 Flying start**

**(FLYING START)**

**Settings:**

★ Disable (DISABLE) [0]  
OK - same direction (OK-SAME DIRECTION) [1]  
OK - both directions (OK-BOTH DIRECTIONS) [2]  
DC-brake before start  
(DC-BRAKE BEF. START) [3]

**Function:**

This function makes it possible to 'catch' a motor, which is spinning freely because of a mains drop-out.

**Description of choice:**

Select *Disable* if this function is not required.

*OK - same direction:* Chosen if the motor can only rotate in same direction on cut-in.

*OK - both directions:* Chosen if the motor can rotate in both directions on cut-in.

*DC-brake - before start:* Selected if the motor is to be stopped using DC brake before the motor is ramped up to the desired speed. The DC brake time must be set in parameter 126.

**Limitations:**

1. Too low inertia will cause acceleration of the load, which may be dangerous or prevent successful *Flying start*. Use DC brake instead.
2. If load is driven eg. by "windmilling", the unit might trip due to overvoltage.
3. Below 250 rpm the *Flying start* will not function.

**446 Switching pattern**

**(SWITCH PATTERN)**

**Settings:**

60° AVM (60° AVM) [0]  
★ SFAVM (SFAVM) [1]

**Description of choice:**

Normally it is not necessary for the customer to set this parameter.

★ = factory setting. ( ) = parameter window text. [ ] = value for use in communication via serial communication port

**500 Address (BUS ADDRESS)**

Settings:

- 1 - 126 [1 -126]
- ★ 1 [1]

Function:

This parameter allows specification of the address of each VSM unit. This feature is used in connection with PLC/PC connection.

Description of choice:

The individual VSM unit can be given an address between 1 and 126. The address 0 is used if a master (PLC or PC) wishes to send a telegram that is to be received by all VSM units connected to the serial communication port at the same time. In this case, the VSM unit will not acknowledge receipt. If the number of units connected (VSM units + master) exceeds 31, a repeater is required.

**501 Baudrate (BAUDRATE)**

Settings:

- 300 Baud (300 BAUD) [0]
- 600 Baud (600 BAUD) [1]
- 1200 Baud (1200 BAUD) [2]
- 2400 Baud (2400 BAUD) [3]
- 4800 Baud (4800 BAUD) [4]
- ★ 9600 Baud (9600 BAUD) [5]

Function:

This parameter is for programming the speed at which data is to be transmitted via the serial connection. Baud rate is defined as the number of bits transferred per second.

Description of choice:

The transmission speed of the VSM unit is to be set at a value that corresponds to the transmission speed of the PLC/PC.

**502 Coasting (COASTING SELECT)**

**503 Quick-stop (Q STOP SELECT)**

**504 DC-brake (DC BRAKE SELECT)**

**505 Start (START SELECT)**

**506 Reversing (REVERSING SELECT)**

**507 Selection of Setup (SETUP SELECT)**

**508 Selection of speed (PRES.REF. SELECT)**

Settings:

- Digital input (DIGITAL INPUT) [0]
- Bus (SERIAL PORT) [1]
- Logic and (LOGIC AND) [2]
- ★ Logic or (LOGIC OR) [3]

Function:

Parameters 502-508 allow a choice between controlling the VSM unit via the terminals (digital input) and/or via the bus.

If *Logic and* or *Bus* is selected, the command in question can only be activated if transmitted via the serial communication port. In the case of *Logic and*, the command must additionally be activated via one of the digital inputs.

Description of choice:

*Digital input* [0] is selected if the control command in question is only to be activated via a digital input.

*Bus* [1] is selected if the control command in question is only to be activated via a bit in the control word (serial communication).

*Logic and* [2] is selected if the control command in question is only to be activated when a signal is transmitted (active signal = 1) via both a control word and a digital input.

Digital input	Bus	Control command
505-508		
0	0	0
0	1	0
1	0	0
1	1	1

*Logic or* [3] is selected if the control command in question is to be activated when a signal is given (active signal = 1) either via a control word or via a digital input.

★ = factory setting. ( ) = parameter window text. [ ] = value for use in communication via serial communication port

**VSM**

Digital input

505-508	Bus	Control command
0	0	0
0	1	1
1	0	1
1	1	1

**NB!**

Parameters 502-504 deal with stop functions - see examples regarding 502 (coasting) below. Active stop command "0".

 Parameter 502 = *Logic and*

Digital input	Bus	Control command
0	0	1 Coasting
0	1	0 Motor running
1	0	0 Motor running
1	1	0 Motor running

 Parameter 502 = *Logic or*

Digital input	Bus	Control command
0	0	1 Coasting
0	1	1 Coasting
1	0	1 Coasting
1	1	0 Motor running

**509 Bus jog 1 (BUS JOG 1 FREQ.)**

Settings:

0.0 - parameter 202 [0 - ]  
 ★ 10.0 Hz [100]

**Function:**

This is where to set a fixed speed (jog) that is activated via the serial communication port.

This function is the same as in parameter 213.

**Description of choice:**

The jog frequency  $f_{JOG}$  can be selected in the range between  $f_{MIN}$  (parameter 201) and  $f_{MAX}$  (parameter 202).

**510 Bus jog 2 (BUS JOG 2 FREQ.)**

Settings:

0.0 - parameter 202 [0 - ]  
 ★ 10.0 Hz [100]

**Function:**

This is where to set a fixed speed (jog) that is activated via the serial communication port.

This function is the same as in parameter 213.

**Description of choice:**

The jog frequency  $f_{JOG}$  can be selected in the range between  $f_{MIN}$  (parameter 201) and  $f_{MAX}$  (parameter 202).

**512 Telegram profile (TELEGRAM PROFILE)**

Settings:

Profdrive (PROFIDRIVE) [0]  
 ★ VSM unit (FC DRIVE) [1]

**Function:**

There is a choice of two different control word profiles.

**Description of choice:**

Select the desired control word profile.

See chapter 9, serial communication, for further information about the control word profiles.

**NB!**

This is only possible in Stop Mode (motor stopped on a Stop command).

**513 Bus time interval (BUS TIMEOUT TIME)**

Value:

1 - 99 sec. ★ 1 sec.

**Function:**

This parameter sets the maximum time expected to pass between the receipt of two consecutive telegrams. If this time is exceeded, the serial communication is assumed to have stopped and the desired reaction is set in parameter 514.

**Description of choice:**

Set the desired time.

★ = factory setting. ( ) = parameter window text. [ ] = value for use in communication via serial communication port

**514 Bus time interval function  
(BUS TIMEOUT FUNC)**

Value:

★ Off (OFF)	[0]
Freeze output (FREEZE OUTPUT)	[1]
Stop (STOP)	[2]
Jogging (JOGGING)	[3]
Max. speed (MAX SPEED)	[4]
Stop and trip (STOP AND TRIP)	[5]

**Function:**  
This parameter selects the desired reaction of the VSM unit when the set time for bus timeout (parameter 513) has been exceeded. If choices [1] to [5] are activated, relay 01 and relay 04 will be de-activated.

**Description of choice:**  
The output frequency of the VSM unit can: be frozen at the present value, be frozen at the reference, go to stop, go to jogging frequency (parameter 213), go to max. output frequency (parameter 202) or stop and activate a trip.

**515 Data read-out: Reference %  
(REFERENCE)**

Value:

XXX.X %	[XXXX]
---------	--------

**Function:**  
This parameter can be read out via the serial communication port.

**Description of choice:**  
The value shown corresponds to the total reference (sum of digital/analogue/preset/bus/freeze ref./catch-up and slow-down).  
This value is updated every 320 ms.

**516 Data read-out: Reference unit  
(REFERENCE [UNIT])**

Value:

X.XXX Hz or rpm.	[XXXX]
------------------	--------

**Function:**  
This parameter can be read out via the serial communication port.

**Description of choice:**  
Indicates the status value of the unit given on the basis of the choice of the reference sum.  
This value is updated every 320 ms.

**517 Data read-out: Feedback  
(FEEDBACK [UNIT])**

Value:

X.XXX	[XXXX]
-------	--------

**Function:**  
This parameter can be read out via the serial communication port.

**Description of choice:**  
Indicates the status value of terminals 1/2 at the unit/scale selected in parameters 414 and 415.  
This value is updated every 320 ms.

**518 Data read-out: Frequency  
(FREQUENCY)**

Value:

XXX.X Hz	[XXXX]
----------	--------

**Function:**  
This parameter can be read out via the serial communication port.

**Description of choice:**  
The value shown corresponds to the actual motor frequency.  
This value is updated every 320 ms.

**519 Data read-out: Frequency x scale  
(FREQUENCY X SCALE)**

Value:

XXX.X Hz	[XXXX]
----------	--------

**Function:**  
This parameter can be read out via the serial communication port.

**Description of choice:**  
The value corresponds to the present output frequency  $f_M$  multiplied by the factor preset in parameter 008 *Display scaling* of output frequency.

★ = factory setting. ( ) = parameter window text. [ ] = value for use in communication via serial communication port

**520 Data read-out: Current (MOTOR CURRENT)**

Value: XXX.XX A [XXXXX]

**Function:**  
This parameter can be read out via the serial communication port.

**Description of choice:**  
The value shown is a calculated value of the given motor current.

This value is updated every 320 ms.

**521 Data read-out: Torque (TORQUE)**

Value: XXX.X % [XXXX]

**Function:**  
This parameter can be read out via the serial communication port.

**Description of choice:**  
The value shown is the torque, with sign, supplied to the motor shaft. The value is given as a percentage of the rated torque.

There is not exact linearity between 160% motor current and torque in relation to the rated torque. Some motors supply more torque than that. Consequently, the min. value and the max. value will depend on the max. motor current as well as the motor used.

This value is updated every 320 ms.

**NB!**  If the setting of the motor parameters does not match the motor applied, the read-out values will be inaccurate and may become negative, even if the motor is not running or is producing a positive torque.

**522 Data read-out: Power, kW (POWER (kW))**

Value: XX.XX kW [XXXX]

**Function:**  
This parameter can be read out via the serial communication port.

**Description of choice:**  
The value shown is calculated on the basis of the actual motor voltage and motor current.

This value is updated every 320 ms.

**523 Data read-out: Power, HP (POWER (hp))**

Value: XX.XX HP (US) [XXXX]

**Function:**  
This parameter can be read out via the serial communication port.

**Description of choice:**  
The value shown is calculated on the basis of the actual motor voltage and motor current. The value is indicated in the form of HP.

This value is updated every 320 ms.

**524 Data read-out: Motor voltage (MOTOR VOLTAGE)**

Value: XXX.X V [XXXX]

**Function:**  
This parameter can be read out via the serial communication port.

**Description of choice:**  
The value shown is a calculated value used for controlling the motor.

This value is updated every 320 ms.

★ = factory setting. ( ) = parameter window text. [ ] = value for use in communication via serial communication port

**525 Data read-out: DC link voltage  
(DC LINK VOLTAGE)**

Value:  
XXXX V [XXXX]

**Function:**  
This parameter can be read out via the serial communication port.

**Description of choice:**  
The value shown is a measured value.

The value is filtered, which means that approx. 1.3 seconds may pass from an input value changes until the data read-out changes values.

This value is updated every 320 ms.

**527 Data read-out: therm.  
( THERMAL)**

Value:  
0 - 100% [0 - 100]

**Function:**  
This parameter can be read out via the serial communication port.

**Description of choice:**  
Only whole numbers are displayed.

This value is updated every 160 ms.

**528 Data read-out: Digital input  
(DIGITAL INPUT)**

Value:  
Unit

**Function:**  
This parameter can be read out via the serial communication port.

**Description of choice:**  
The value shown indicates the signal status from the 4 digital terminals (2, 3, 4, and 5).

This value is updated every 20 ms.

**533 Data read-out: External reference %  
(EXT. REFERENCE)**

Value:  
-200.0 - +200.0 %

**Function:**  
This parameter can be read out via the serial communication port.

**Description of choice:**  
The value stated gives, as a percentage, the sum of external references (sum of analogue/bus/pulse).

This value is updated every 80 ms.

**534 Data read-out: Status word, binary  
(STATUS WORD [HEX])**

Value:  
Unit

**Function:**  
This parameter can be read out via the serial communication port.

**Description of choice:**  
Indicates the status word transmitted via the serial communication port.

★ = factory setting. ( ) = parameter window text. [ ] = value for use in communication via serial communication port

**537 Data read-out: temperature (INVERTER TEMP.)**

Value:  
Unit: °C

**Function:**  
This parameter can be read out via the serial communication port.

**Description of choice:**  
States the given temperature of the frequency converter. This value is updated every 10 sec.

**538 Data read-out: Alarm word (ALARM WORD)**

Value:  
Unit

**Function:**  
This parameter can be read out via the serial communication port. See chapter on "Warnings and alarms".

**Description of choice:**  
States whether there is an alarm on the VSM unit.

Hex	Fault messages
00000002	Trip lock
00000040	HPFB timeout
00000080	Standard bus timeout
00000100	Short circuit
00000200	24 V supply fault
00000400	Earth fault
00000800	Overcurrent
00004000	Motor thermistor
00008000	Inverter overload
00010000	Undervoltage
00020000	Overvoltage
00040000	Phase loss
00080000	Live zero error
00100000	Overtemperature
02000000	HPFB error
08000000	Inrush fault
10000000	Internal error

 **NB!** This parameter is updated every 20 ms.

**539 Data read-out: Control word (CONTROL WORD)**

Value:  
Unit

**Function:**  
This parameter can be read out via the serial communication port.

**Description of choice:**  
Indicates the control word sent via the serial communication port in Hex code from the VSM unit. This parameter is updated every 20 ms.

**540 Data read-out: Warning word, 1 (WARN. WORD 1)**

Value:  
Unit

**Function:**  
This parameter can be read out via the serial communication port. See chapter on "Warnings and alarms".

**Description of choice:**  
States in Hex format whether there is a warning on the VSM unit.

Hex	Warning messages
00000008	HPFB timeout
00000010	Standard bus timeout
00000040	Current limit
00000200	Inverter overload
00001000	Voltage warning low
00002000	Voltage warning high
00004000	Phase loss
00010000	Live zero error warning
00400000	Output freq. limit warning
00800000	HPFB error
40000000	24 V supply warning
80000000	Inverter temp. high

**541 Data read-out: Warning word, 2 (WARN. WORD 2)**

Value:  
Unit

**Function:**  
This parameter can be read out via the serial communication port.

★ = factory setting. ( ) = parameter window text. [ ] = value for use in communication via serial communication port

**Description of choice:**

States in Hex format whether there is a warning on the VSM unit.

Hex	Status messages
01	Ramping
04	Start clockwise/counterclockwise
08	Slow down
10	Catch-up
8000	Frequency limit

**542 Data read-out: Terminal 1, analogue input (ANALOG INPUT 1)**

**Value:**

Unit: mA

**Function:**

This parameter can be read out via the serial communication port.

**Description of choice:**

The value shown indicates the signal value on terminal 1.

The scaling (parameters 336 and 337) does not influence the read-out. Min. and max. are determined by the offset and gain adjustment of the AD-converter.

This value is updated every 20 ms.

**543 Data read-out: Terminal 2, analogue input (ANALOG INPUT 2)**

**Value:**

Unit: X.X V

**Function:**

This parameter can be read out via the serial communication port.

**Description of choice:**

The value shown indicates the signal value on terminal 2.

The scaling (parameters 338 and 339) does not influence the read-out. Min. and max. are determined by the offset and gain adjustment of the AD-converter.

This value is updated every 20 ms.

**600 Operating data: Operating hours (OPERATING HOURS)**

**Value:**

Unit: hours  
0.0 - 130,000.0

**Function:**

This parameter can be read out via the display or the serial communication port. The value cannot be reset.

**Description of choice:**

Indicates the number of hours in which the VSM unit has been switched on.

The value is updated in the VSM unit every hour and saved when the unit is turned off.

**601 Operating data: Hours run (RUNNING HOURS)**

**Value:**

Unit: hours  
0.0 - 130,000.0

**Function:**

This parameter can be read out via the display or the serial communication port. The value can be reset via parameter 619.

**Description of choice:**

Indicates the number of hours in which the VSM unit has been in operation since reset in parameter 619.

The value is updated in the VSM unit every hour and saved when the unit is turned off.

**603 Operating data: Number of power-up's (POWER UP'S)**

**Value:**

Unit: number  
0 - 9999

**Function:**

This parameter can be read out via the display or the serial communication port.

**Description of choice:**

States the number of power-ups of the supply voltage to the VSM unit.

★ = factory setting. ( ) = parameter window text. [ ] = value for use in communication via serial communication port

**604 Operating data: Number of overtemperatures (OVER TEMP'S)**

**Value:**  
Unit: number  
0 - 9999

**Function:**  
This parameter can be read out via the display or the serial communication port.

**Description of choice:**  
States the number of temperature faults there has been on the VSM unit.

**605 Operating data: Number of overvoltages (OVER VOLT'S)**

**Value:**  
Unit: number  
0 - 9999

**Function:**  
This parameter can be read out via the display or the serial communication port.

**Description of choice:**  
States the number of overvoltages there has been on the VSM unit.

**615 Fault log: Error code (F.LOG: ERROR COD)**

**Value:**  
[Index XX - XXX]

**Function:**  
Array type parameter. This parameter makes it possible to see the reason why a trip occurs.

10 log values are stored.

The lowest log number (1) contains the latest/most recently saved data value; the highest log number (10) contains the oldest data value.

For additional information, see chapter on "Warnings and alarms".

**Description of choice:**  
Read out as a figure code between 1 and 37.

Fault code	Alarm
0	No fault
1	
2	Live zero error
3	
4	Phase loss
7	Overvoltage
8	Undervoltage
9	Inverter overload
11	Motor thermistor
13	Overcurrent
14	Earth fault
15	Supply fault
16	Short circuit
17	Standard BUS time out
18	HPFB time out
34	HPFB error
35	Inrush fault
36	Overtemperature
37	Internal error

The fault log is reset after initialisation in parameter 620.

**616 Fault log: Time (F.LOG: TIME)**

**Value:**  
Unit: Hours  
[Indication range XX - XXX]

**Function:**  
Array type parameter. This parameter makes it possible to see the total number of operating hours before the trip occurred.  
10 (1-10) log values are stored.

The lowest log number (1) contains the latest/most recently saved data value, while the highest log number (10) contains the oldest data value.

**Description of choice:**  
Read out as an option.

Indication range: XX - XXX.

The fault log is reset after initialisation (para. 620).

★ = factory setting. ( ) = parameter window text. [ ] = value for use in communication via serial communication port

**617 Fault log: Value  
(F.LOG: VALUE)**

**Value:**

[Index XX - XXX]

**Function:**

Array type parameter. This parameter makes it possible to see at what current or voltage a given trip occurred.

**Description of choice:**

Read out as one value.

Indication range: 0.0 - 999.9.

The fault log is reset after initialisation (para. 620).

**619 Reset of hours-run counter  
(RESET RUN. HOUR)**

**Settings:**

- ★ No reset (DO NOT RESET) [0]
- Reset (RESET COUNTER) [1]

**Function:**

Reset to zero of hours-run counter (parameter 601).

**Description of choice:**

If *Reset* [1] has been selected the hours-run counter of the FC motor is reset.

**620 Operating mode (OPERATION MODE)**

**Settings:**

- ★ Normal function (NORMAL OPERATION) [0]
- Control card test (CONTROL CARD TEST) [2]
- Initialisation (INITIALIZE) [3]

**Function:**

In addition to its normal function, this parameter can be used for two different tests.

Also, all parameters (except parameters 603-605) can be initialised.

**Description of choice:**

*Normal function* [0] is selected for normal operation with the motor in the selected application.

*Control card test* [2] is selected if control of the analogue and digital inputs, as well as the analogue, digital outputs and the +10 V control voltage is desired.

A test connector with internal connections is required for this test. Setup: Analogue/digital output to digital inputs 3, 4 and 5 and 10 V supply to analogue/digital input 2.

*Initialisation* [3] is selected if the factory setting of the unit is desired without resetting parameters 500, 501 + 600 - 605. Initialisation is active after power up.

**621 Nameplate: VSM type (VSM TYPE)**

**Value:**

Depends on unit

**Function:**

The key data of the unit can be read out via the serial communication port.

**Description of choice:**

*Type* indicates the unit size and basic function concerned.

**624 Nameplate: Software version no.  
(SOFTWARE VERSION)**

**Value:**

Depends on unit

**Function:**

The key data of the unit can be read out the serial communication port.

**Description of choice:**

*Software version* gives the version number.

**625 Nameplate: LCP identification no.  
(LCP VERSION)**

**Value:**

Depends on unit

**Function:**

The key data of the unit can be read out via the display or the serial communication port. For example: ID 1,42 2 kB.

★ = factory setting. ( ) = parameter window text. [ ] = value for use in communication via serial communication port

**626 Nameplate: Database identification no.  
(DATABASE VER.)**
**Value:**

Depends on unit

**Function:**

 The key data of the unit can be read out via the display or the serial communication port.
 

---

**628 Nameplate: Application option type  
(APP. OPTION)**
**Value:**
**Function:**

 The key data of the unit can be read out via the display or the serial communication port.
 

---

**630 Nameplate: Communication option type  
ordering no. (COM. ORDER NO)**
**Value:**
**Function:**

 The key data of the unit can be read out via the display or the serial communication port.
 

---

**632 BMC software identification  
(BMC SW VERSION)**
**Value:**
**Function:**

 The key data of the unit can be read out via the display or the serial communication port.
 

---

**633 Motor database identification  
(MOTOR DATA VERS.)**
**Value:**
**Function:**

 The key data of the unit can be read out via the display or the serial communication port.
 

---

**634 Unit identification for communication  
(UNIT ID)**
**Value:**
**Function:**

 The key data of the unit can be read out via the display or the serial communication port.
 

---

**635 Software part No  
(SW. PART NO:)**
**Value:**
**Function:**

 Indicates the software part No.
 

---

 For information on the Profibus parameter group 800 - 900, see the VSM Profibus manual MG.03.EX.YY.
 

---

★ = factory setting. ( ) = parameter window text. [ ] = value for use in communication via serial communication port

**Chapter 9**

- PC software ..... page 72
- Serial bus ..... page 73
- Telegram communication ..... page 73
- Telegram build-up ..... page 73
- Data bytes ..... page 74

**■ PC software for serial communication**

Using serial communication makes it possible to monitor, programme and control one or several VSM units from a centrally placed computer. All Variable speed W motors have an RS 485 port as standard, which enables them to communicate e.g. with a PC. A programme entitled Software Dialog is available for this purpose.

Software Dialog comes in three modules and - as a minimum - contains the programmes included in the Basic module.

The Basic module covers:

---

**TEST RUN**

is used for controlling and commissioning of a VSM unit, including:

- setting of reference value,
- simultaneous display of selected parameters in graphs,
- option of DDE link, e.g. to a spreadsheet.

**PARAMETER SETUP**

is used for setting up and transferring parameter sets, including:

- setting of VSM unit parameters,
- parameter sets can be obtained from and copied to a VSM unit,
- documentation/print-out of the Setup including diagrams.

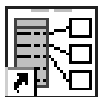
**BUS ADDRESS SETUP**

is used for setting the bus addresses on individual VSM units which are connected to the same bus.

- setting bus addresses
- storing list of units
- reporting list of units

The Logging module covers:

---

**LOGGING**

is used for collecting and displaying historical or real-time operating data:

- graphical representation of selected parameters from several VSM units,
- collection of log data to file,
- option of DDE link e.g. to a spreadsheet.

**MODEM SETUP**

is used for setting up the modem.

- sets the VSM unit modem via the communication port of the PC.

The template module covers:

---

**TEMPLATE SETUP**

is used for setting up template files for PARAMETER SETUP:

- the template file functions as a mask that limits the number of accessible parameters when a parameter file is to be made or edited in PARAMETER SETUP,
- the template file may contain preset values for the parameters of the VSM unit.

**NB!**

The logging and template module calls for a Basic module to be installed on the same PC.

The guided tour covers:

---

**GUIDED TOUR**

offers a demonstration of the Software Dialog programme.

---

■ Serial bus

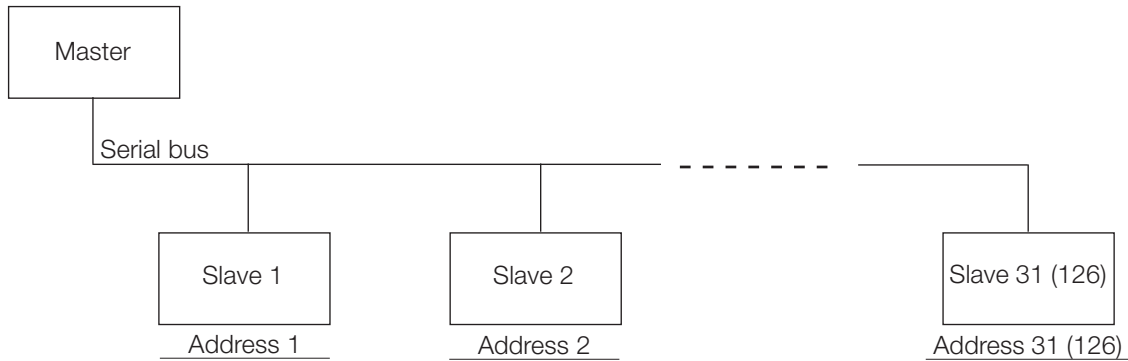

■ Telegram communication

Control and reply telegrams

The telegram communication in a master/slave system is controlled by the master. A maximum of 31 slaves (VSM) can be connected to one master, unless a repeater is used - see also the description of the address format.

The master continuously sends control telegrams addressed to the slaves and awaits reply telegrams from these. The response time of the slaves is maximum 50 ms.

Only a slave that has received a faultless telegram addressed to that slave will respond by sending back the telegram unchanged.

Broadcast

A master can send the same telegram at the same time to all slaves connected to the bus. In such *broadcast* communication, the control telegram *broadcast* bit of the address bit has a value of 1 (see *VLT address*). Address bits 0-4 are not used.

Contents of a byte

Each transmitted sign begins with a start bit. Subsequently, 8 databits are transmitted. Each sign is given via a parity bit set at "1" when there is an even parity (i.e. an even number of binary 1's in the 8 databits and parity bits together). The sign ends with a stop bit and thus consists of a total of 11 bits.

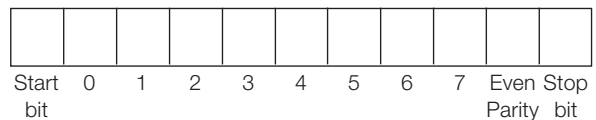

■ Telegram build-up

Each telegram begins with a startbyte (STX) = 02 Hex, followed by a byte that gives the telegram length (LGE) and a byte that gives the address (ADR). Then follows a number of databytes (variable, depending on telegram type). The telegram ends with a data control byte (BCC).

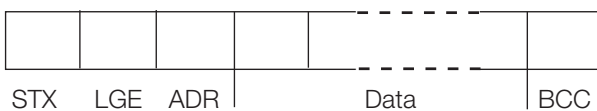

Telegram length (LGE)

The telegram length is the number of databytes plus address byte ADR plus data control byte BCC.

Telegrams with 4 databytes have a length of:  
LGE = 4 + 1 + 1 = 6 bytes

Telegrams with 12 databytes have a length of:  
LGE = 12 + 1 + 1 = 14 bytes

VSM address (ADR)

Two different address formats are used:

1. Siemens USS protocol address format:

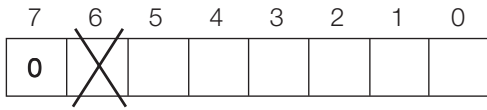

Bit 7 = 0

Bit 6 is not used

Bit 5 = 1: Broadcast, address bits (0-4) are not used

Bit 5 = 0: No Broadcast

Bits 0-4 = VLT address 1-31

2. Brook crompton format:

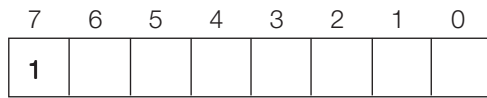

Bit 7 = 1

Bits 0-6 = VLT address 1-127 (0 = Broadcast)

Data control byte (BCC)

The data control byte can best be explained by means of an example: Before the first sign of the telegram is received, BCC = 0.

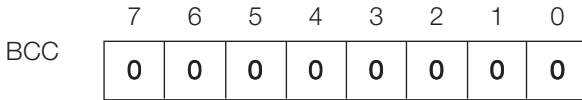

After the first sign has been received:

$$BCC_{NEW} = BCC_{OLD} \text{ EXOR "first byte"}$$

(EXOR = exclusive-or gate)

$$BCC_{OLD} = 00000000$$

$$\text{"first byte"} = 00000010 \text{ (02H)}$$

$$BCC_{NEW} = 00000010$$

Each additional, subsequent byte is gated by  $BCC_{OLD}$  EXOR and gives a new  $BCC_{NEW}$ , e.g.:

$$BCC_{OLD} = 00000010$$

$$\text{"second byte"} = 11010110 \text{ (D6H)}$$

$$BCC_{NEW} = 11010100$$

The result after the last received sign is BCC.

■ **Databytes**

The block of databytes is divided into two smaller blocks:

1. Parameter bytes used for transferred parameters between master and slave
2. Process bytes, covering
  - Control word and reference value (from master to slave)
  - Status word and present output frequency (from slave to master)

This structure applies to both the control telegram (master→slave) and the reply telegram (slave→master).

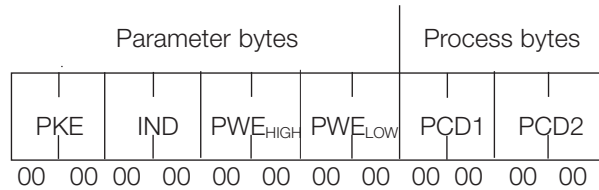

There are two types of telegrams:

- with 12 bytes built up as shown above, with parameter and process block
- with four bytes, which is the process block from the 12 byte telegram

1. Parameter bytes

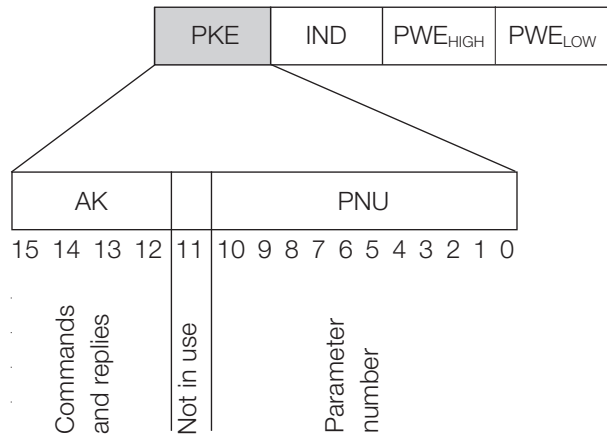

Commands and replies (AK)

Bits no. 12-15 are used for transmitting commands from master to slave and the slave's processed reply back to the master.

Commands master→slave:

Bit no.

15	14	13	12	Command
0	0	0	0	No command
0	0	0	1	Read parameter value
0	0	1	0	Write parameter value in RAM (word)
0	0	1	1	Write parameter value in RAM (double word)
1	1	0	1	Write parameter value in RAM and EEPROM (double word)
1	1	1	0	Write parameter value in RAM and EEPROM (word)
1	1	1	1	Read text

Reply slave→master:

Bit no.

15	14	13	12	Reply
0	0	0	0	No reply
0	0	0	1	Parameter value transferred (word)
0	0	1	0	Parameter value transferred (double word)
0	1	1	1	Command cannot be executed
1	1	1	1	Text transferred

If the command cannot be executed, the slave will send this reply (0111) and give the following error message in the parameter value:

Error code

(reply 0111)	Error message
0	The parameter number used does not exist
1	There is no write access to the parameter called
2	The data value exceeds the parameter limits
3	The used sub-index does not exist
4	The parameter is not of the array type
5	The data type does not match the parameter called
17	Data change in the parameter called is not possible in the present mode of the VMS unit. E.g. some parameters can only be changed when the motor has stopped
130	There is no bus access to the parameter called
131	Data change is not possible because factory Setup has been selected

Parameter number (PNU)

Bits no. 0-10 are used for transmitting parameter numbers. The function of a given parameter can be seen from the parameter description in chapter 8.

PKE	IND	PWE
-----	-----	-----

Index

Index is used together with the parameter number for read/write access to parameters of the *array* type (par. 615, 616 and 617).

Parameter value (PWE)

PKE	IND	PWE
-----	-----	-----

The parameter value depends on the command given. If the master wants a parameter (read), it does not care about the PWE block value. If a parameter is changed by the master (write), the new value is transferred in the PWE block. If the slave replies to a parameter request (read command), the present parameter value is transferred to the PWE block.

The transferred value corresponds to the figures given in the parameter descriptions in chapter 8. E.g. parameter 101, where [1] corresponds to *Constant torque*, [2] corresponds to *Variable torque: low*, etc. However, parameters with data type 9 (text string) are excepted, as this text is transferred as an ASCII text string. When a text string is transferred (read), the telegram length is variable, since the texts have different lengths. The telegram length is stated in the 2nd byte of the telegram, called LGE, see page 73. Parameters 621-634 (nameplate data) have data type 9 (text string).

Data types supported by the frequency converter

Data type	Description
3	Integer 16
4	Integer 32
5	Unsigned 8
6	Unsigned 16
7	Unsigned 32
9	Text string

Unsigned means there is no sign included in the telegram.

The different attributes for each parameter can be seen in the section on factory settings. Since a parameter value can only be transferred as an integer, a conversion factor must be used to transfer decimals.

Example:

Parameter 201: minimum frequency, conversion factor 0,1. If parameter 201 is to be set to 10 Hz, a value of 100 must be transferred, since a conversion factor of 0,1 means that the transferred value will be multiplied by 0.1. A value of 100 will thus be understood as 10.

Addressing by unit ID

The unit ID is printed on the label on the plastic cover under the lid of the electronics box. The three groups of unit ID each with three digits must be converted to Hex. The desired address is added as the last byte. The frame is sent to the bus address parameter(s) 500 (and 918) via a broadcast.

Unit ID:		0-255	0-255	1-255	
		↓	↓	↓	
PKE	IND	00-FF	00-FF	01-FF	Address

PKE: Write to parameter No. 500 or 918

IND: Not Used

2. Process-bytes

The process byte block is divided into two blocks each of 16 bits, which always come in the sequence stated.



	PCD1	PCD2
Control telegram (master→slave)	Control word	Reference value
Reply telegram (slave→master)	Status word	Given output frequency

(parameter 512 = Profdrive)

The control word is used for transmitting commands from a master (e.g. a PC) to a slave (VSM unit).

Master→Slave

Control word	Bus reference
--------------	---------------

15	14	13	12	11	10	9	8	7	6	5	4	3	2	1	0	Bit no.
Bit = 0															Bit =1	
00	OFF 1														ON 1	
01	OFF 2														ON 2	
02	OFF 3														ON 3	
03	Motor coasting														Enable	
04	Quick-stop														Ramp	
05	Freeze output frequency														Ramp enable	
06	Ramp stop														Start	
07	No function														Reset	
08	Jog 1 OFF														ON	
09	Jog 2 OFF														ON	
10	Data not valid														Valid	
11	No function														Slow down	
12	No function														Catch-up	
13	Choice of Setup															
14																
15	No function														Reversing	

Bit 00, OFF1/ON1:

An ordinary ramp stop which uses the ramp time in parameters 207/208. Bit 00 = "0" leads to a stop and to output being activated, the output frequency is 0 Hz, provided OFF 123 has been selected in parameter 340. Bit 00 = "1" means that the frequency converter will be able to start if the other conditions for starting have been fulfilled.

Bit 01, OFF2/ON2:

Coasting stop. Bit 01 = "0" leads to a coasting stop and leads to output being activated, when the output frequency is 0 Hz, provided OFF 123 has been selected in parameter 340. Bit 01 = "1" means that the frequency converter is able to start, provided the other conditions for starting are fulfilled.

Bit 02, OFF3/ON3:

Quick-stop, which uses the ramp time in parameter 212. Bit 02 = "0" leads to a quick-stop and leads to output being activated, when the output frequency is 0 Hz, provided OFF 123 has been selected in parameter 340. Bit 02 = "1" means that the frequency converter is able to start, provided the other conditions for starting are fulfilled.

Bit 03, Coasting/enable:

Coasting. Bit 03 = "0" leads to a stop. Bit 03 = "1" means that the frequency converter is able to start, provided the other conditions for starting are fulfilled. Note: In parameter 502 the choice is made as to how bit 03 is to be combined (gated) with the corresponding function in the digital inputs.

Bit 04, Quick-stop/ramp:

Quick-stop which uses the ramp time in parameter 212. Bit 04 = "0" leads to a quick-stop. Bit 04 = "1" means that the frequency converter is able to start, provided the other conditions for starting are fulfilled.

Note: In parameter 503 the choice is made as to how bit 04 is to be combined (gated) with the corresponding function on the digital inputs.

Bit 05, Freeze output frequency/ramp enable:

Bit 05 = "0" means that the given output frequency is maintained even if the reference is changed. Bit 05 = "1" means that the frequency converter is again able to regulate, and the given reference is followed.

Bit 06, Ramp stop/start:

An ordinary ramp stop that uses the ramp time in parameters 207/208; in addition, output will be activated when the output frequency is 0 Hz, provided *OFF 123* has been selected in parameter 340. Bit 06 = "0" leads to a stop. Bit 06 = "1" means that the frequency converter is able to start, provided the other conditions for starting are fulfilled. Note: In parameter 505 the choice is made as to how bit 06 is to be combined (gated) with the corresponding function on the digital inputs.

Bit 07, No function/reset

Reset of trip. Bit 07 = "0" means that there is no reset. Bit 07 = "1" means that a trip is reset. After reset it will take approx. 1.5 second until the unit is ready. The status word will indicate the ready state.

Bit 08, Jog 1 OFF/ON:

Activation of pre-programmed speed in parameter 509 (Bus JOG 1). JOG 1 is only possible when Bit 04 = "0" and bit 00-03 = "1".

Bit 09, Jog 2 OFF/ON:

Activation of pre-programmed speed in parameter 510 (Bus JOG 2). JOG 2 is only possible when Bit 04 = "0" and Bits 00-03 = "1". If both JOG 1 and JOG 2 are activated (Bits 08 and 09 = "1"), JOG 1 has the higher priority, which means that the speed programmed in parameter 509 will be used.

Bit 10, Data not valid/valid:

Used for telling the VSM unit whether the control word is to be used or ignored. Bit 10 = "0" means that the control word is ignored. Bit 10 = "1" means that the control word is used. This function is relevant because the control word is always contained in the telegram, regardless of the type of telegram used, i.e.

it is possible to disconnect the control word if it is not to be used in connection with updating or reading of parameters.

Bit 11, No function/slow down:

Used for reducing the speed reference by the value in parameter 219. Bit 11 = "0" means that there is no change of the reference. Bit 11 = "1" means that the reference is reduced.

Bit 12, No function/catch-up:

Used for increasing the speed reference by the value of parameter 219. Bit 12 = "0" means that there is no change of the reference; Bit 12 = "1" means that the reference is increased. If both slow down and catch-up are activated (Bits 11 and 12 = "1"), slow down has the higher priority, i.e. the speed reference is reduced.

Bits 13, Choice of Setup:

Bit 13 is used for choosing between the two menu Setups in accordance with the following table:

Setup	Bit 13
1	0
2	1

This function is only possible if *Multi-Setups* have been selected in parameter 004.



**NB!**

Parameter 507 is used for choosing how Bit 13 is to be combined (gated) with the corresponding function on the digital inputs.

Bit 15, No function/reversing:

Reversing of the direction of rotation of the motor. Bit 15 = "0" leads to no reversing, Bit 15 = "1" leads to reversing.



**NB!**

Unless otherwise mentioned, the control word bit is combined (gated) with the corresponding function on the digital inputs as a logic "or" function.

Status word (according to profidrive standard)  
The status word is used for informing the master (e.g. a PC) of the condition of a slave (VSM unit).

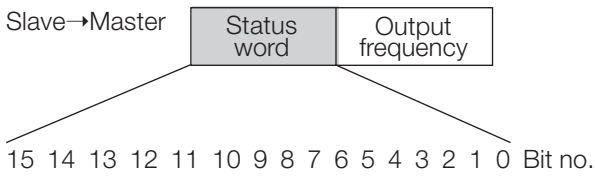

Bit	Bit = 0	Bit = 1
00	Control not ready	Ready
01	VSM not ready	Ready
02	Motor coasting	Enable
03	No fault	Trip
04	ON 2	OFF 2
05	ON 3	OFF 3
06	Start enable	Start disable
07	No warning	Warning
08	Speed ≠ ref.	Speed = ref.
09	Reserved	
10	Reserved	
11	Not running	Running
12	VSM OK	Stalls, auto-start
13	Voltage OK	Above limit
14	Torque OK	Above limit
15	Timer OK	Above limit

Bit 00, Control not ready/ready:

Bit 00 = "0" means that bit 00, 01 or 02 of the control word is "0" (OFF1, OFF2 or OFF3), or that the frequency converter has tripped. Bit 00 = "1" means that the frequency converter control is ready.

Bit 01, VSMnot ready/ready:

Same meaning as bit 00; however, there is also a supply to the power section, and the frequency converter is ready to run when it receives the necessary start signals.

Bit 02, Coasting/enable:

Bit 02 = "0" means that the control word bit 00, 01, 02 or 03 is "0" (OFF1, OFF2, OFF3 or Coasting), or the FCM 300 Series unit has tripped. Bit 02 = "1" means that the control word bits 00, 01, 02 or 03 are "1" and that the VSM unit has not tripped.

Bit 03, No fault/trip:

Bit 03 = "0" means that FCM 300 Series is not in a fault condition. Bit 03 = "1" means that VSM unit has tripped and needs a reset signal in order to run.

Bit 04, ON2/OFF2:

Bit 04 = "0" means that control word bit 01 = "1".  
Bit 04 = "1" means that control word bit 01 = "0".

Bit 05, ON3/OFF3:

Bit 05 = "0" means that control word bit 02 = "1".  
Bit 05 = "1" means that control word bit 02 = "0".

Bit 06, Start enable/start disable:

Bit 06 is always "0" if VSM has been selected in parameter 512. If Profidrive has been selected in parameter 512, bit 06 will be "1" after reset of a trip, after activation of OFF2 or OFF3 and after connection of mains voltage. *Start disable* is reset, setting control word bit 00 to "0" and bits 01, 02 and 10 to "1".

Bit 07, No warning/warning:

Bit 07 = "0" means that there is no unusual situation. Bit 07 = "1" means that an abnormal condition has arisen for the VSM unit. All warnings described on page 66 will set bit 07 to "1".

Bit 08, Speed ≠ ref/speed. = ref.:

Bit 08 = "0" means that the actual motor speed is different from the speed reference set. This can be the case i.a. while the speed is ramped up/down during start/stop. Bit 08 = "1" means that the present motor speed equals the speed reference set.

Bit 11, Does not run/runs:

Bit 11 = "0" means that the motor is not running.  
Bit 11 = "1" means that the VSM unit has a start signal or that the output frequency is greater than 0 Hz.

Bit 12, FC OK/stalling, autostart:

Bit 12 = "0" means that there is no temporary overtemperature on the inverter. Bit 12 = "1" means that the inverter has stopped because of overtemperature, but that the unit has not tripped and will continue, once the overtemperature stops.

Bit 13, Voltage OK/above limit:

Bit 13 = "0" means that the voltage limits of the VSM unit have not been exceeded. Bit 13 = "1" means that the DC voltage of the VSM unit intermediate circuit is too low or too high.

Bit 14, Torque OK/above limit:

Bit 14 = "0" means that the motor current is lower than the torque limit selected in parameter 221. Bit 14 = "1" means that the torque limit in parameter 221 has been exceeded.

Bit 15, Timers OK/above limit:

Bit 15 = "0" means that the timers for motor thermal protection and inverter thermal protection, respectively, have not exceeded 100%. Bit 15 = "1" means that one of the timers has exceeded 100%.

Control word under standard (parameter 512 = VSM unit)

The control word is used for sending commands from a master (e.g. a PC) to a slave (VSM unit).

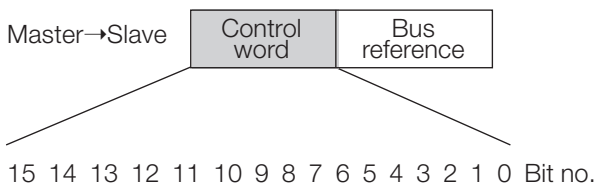

Bit	Bit = 0	Bit = 1
00	Preset reference choice	
01	No function	
02	DC brake	Ramp
03	Coasting	Enable
04	Quick-stop	Ramp
05	Hold	Ramp enable
06	Ramp stop	Start
07	No function	Reset
08	No function	Jog
09	No function	
10	Data not valid	Valid
11	No function	
12	No function	
13	Choice of Setup	
15	No function	Reversing

Bit 00:

Bit 00 is used for choosing between the two pre-programmed references (parameters 215-216) in accordance with the following table:

Preset ref.	Parameter	Bit 00
1	215	0
2	216	1



**NB!**

Parameter 508 is where to choose the way bits 1/12 are to be combined (gated) with the corresponding function on the digital inputs.

Bit 02, DC brake:

Bit 02 = "0" leads to DC braking and stop. Braking current and duration are set in parameters 132 and 133. Bit 02 = "1" leads to *ramp*.

Bit 08, Activation of Jog speed in parameter 213:

Bit 08 = "0": Jog speed not activated. Bit 08 = "1" means that the motor is running at Jog speed.

See the description of other bits under control word for Profidrive standard, page 76.



**NB!**

Unless otherwise mentioned, the control word bit is combined (gated) with the corresponding function on the digital inputs as a logic "or" function.

Status word

The status word is used for informing the master (e.g. a PC) about the condition of the slave (VSM unit).

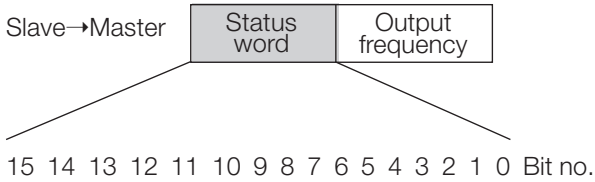

Bit	Bit = 0	Bit = 1
00	Control not ready	Ready
01	FVSMnot ready	Ready
02	Coasting	Enable
03	No fault	Trip
04	Reserved	
05	Reserved	
06	Reserved	
07	No warning	Warning
08	Speed ≠ ref.	Speed = ref.
09	Local control	Bus control
10	Out of range	Frequency OK
11	Not running	Running
12	VSM OK	Stalling, autostart
13	Voltage OK	Above limit
14	Torque OK	Above limit
15	Timer OK	Above limit

Bit 01, Control not ready/ready:

Bit 01 = "0" means that the frequency converter has tripped.

Bit 01 = "1" means that the frequency converter is ready.

Bit 02, Coasting/enable:

Bit 02 = "0" means that the control word bit 03 is "0" (Coasting) or that the VSM unit has tripped.

Bit 02 = "1" means that control word bit 03 is "1" and that the VSM unit has not tripped.

See the description of other bits under status word for the Profidrive standard, page 78.

Bus reference value:

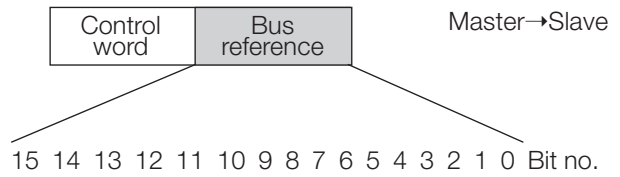

The frequency reference value is transmitted to the frequency converter in the form of a 16-bit word. The value is transmitted as a whole number (0-32767). 16384 (4000 Hex) corresponds to 100%. (Negative figures are formed by means of 2's complement.)

The bus reference has the following format:

Parameter 203 = "0"

$$\text{"ref}_{\text{MIN}} - \text{ref}_{\text{MAX}}"$$

0-16384 (4000 Hex) ~ 0-100% ~  $\text{ref}_{\text{MIN}} - \text{ref}_{\text{MAX}}$

Parameter 203 = "1"

$$-\text{ref}_{\text{MAX}} - +\text{ref}_{\text{MAX}}$$

-16384 (. . . Hex) - +16384 (4000 Hex) ~

-100- +100% ~  $-\text{ref}_{\text{MAX}} - +\text{ref}_{\text{MAX}}$

Actual output frequency

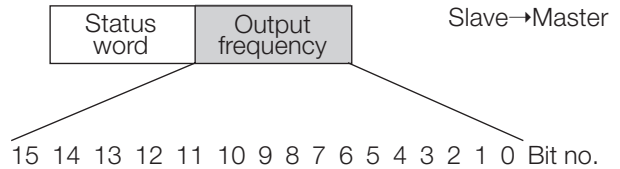

The value of the actual output frequency of the frequency converter is transmitted in the form of a 16-bit word. The value is transmitted as a whole number (0-32767). 16384 (4000 Hex) corresponds to 100%. (Negative figures are formed by means of 2's complement).

**Chapter 10**

- Galvanic isolation ..... page 82
- Earth leakage current ..... page 82
- Extreme running conditions ..... page 83
- Acoustic noise ..... page 83
- Derating ..... page 84
- Derating for ambient temperature ..... page 84
- Derating for air pressure ..... page 84
- Derating for running at low speed ..... page 84
- Derating for high switching frequency ..... page 85
- Vibration and shock ..... page 85
- Air humidity ..... page 85
- Efficiency ..... page 85
- Mains supply interference/harmonics ..... page 86
- Power factor ..... page 86
- What is CE labelling? ..... page 86
- The machinery directive (89/392/EEC) ..... page 86
- The low-voltage directive (73/23/EEC) ..... page 86
- The EMC directive (89/336/EEC) ..... page 87
- What is covered? ..... page 87
- Brook crompton Variable speed W motor  
and CE labelling ..... page 87
- Compliance with EMC directive 89/336/EEC page 87
- EMC standards ..... page 88
- Aggressive environments ..... page 89

■ **Galvanic isolation (PELV)**

PELV offers protection by way of extra low voltage. Protection against electric shock is considered to be ensured when all connected devices are of the PELV type and the installation is made as described in local/national regulations on PELV supplies.

In Variable speed W motor all control terminals are supplied from or in connection with extra low voltage (PELV).

Galvanic (ensured) isolation is obtained by fulfilling requirements concerning higher isolation and by providing the relevant creepage/clearance distances. These requirements are described in the EN 50178 standard.

The components that make up the electrical isolation, as described below, also comply with the requirements concerning higher isolation and the relevant test as described in EN 50178.

The galvanic isolation can be shown in three locations (see drawing below), namely:

1. Power supply (SMPS) incl. signal isolation of  $U_{DC}$ , indicating the intermediate current voltage.
2. Gate drive that runs the IGBTs (opto-couplers).

3. Current transducers (opto-couplers).

■ **Earth leakage current**

Earth leakage current is primarily caused by the capacitance between motor phases and the motor frame. The RFI filter contributes additional leakage current, as the filter circuit is connected to earth through capacitors.

The size of the leakage current to the ground depends on the following factors, in order of priority:

1. Switching frequency
2. Motor grounded on site or not

The leakage current is of importance to safety during handling/operation of the frequency converter if (by mistake) the frequency converter has not been earthed.



**NB!**

Since the leakage current is  $> 3.5$  mA (approx. 4-20 mA), reinforced earthing must be established (see Quick Guide MG.03.A1.02), which is required if EN 50178 is to be complied with. Never use ELCB relays that are not suitable for DC fault currents (type A).

If ELCB relays are used, they must be:

- Suitable for protecting equipment with a direct current content (DC) in the fault current (3-phase bridge rectifier)
- Suitable for power-up with short charging current to earth
- Suitable for a high leakage current.

Galvanic isolation

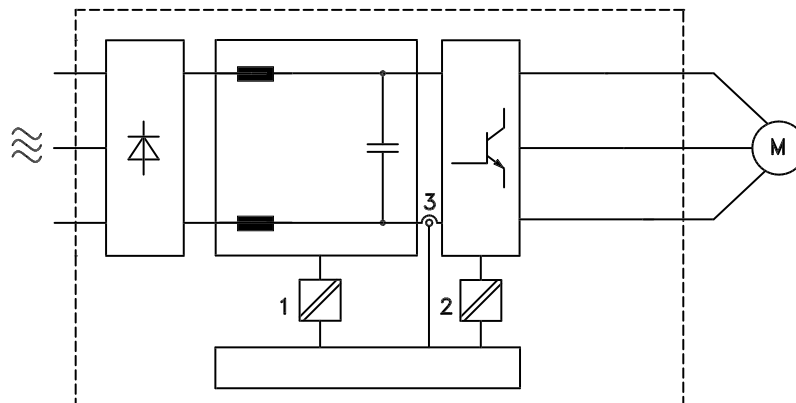

**■ Extreme running conditions**
Motor-generated overvoltage

The voltage in the intermediate circuit is increased when the motor acts as a generator. This occurs in two cases:

1. The load drives the motor (at constant output frequency from the frequency converter), i.e. the load generates energy.
2. During deceleration ("ramp-down") if the moment of inertia is high, the load is low and the ramp-down time is too short for the energy to be dissipated as a loss in the frequency converter, the motor and the installation.

The control unit attempts to correct the ramp if possible.

The inverter turns off to protect the transistors and the intermediate circuit capacitors when a certain voltage level is reached.

Mains drop-out

During a mains drop-out, the VSM units continues until the intermediate circuit voltage drops below the minimum stop level, which is typically 15% below VSM units lowest rated supply voltage.

The time before the inverter stops depends on the mains voltage before the drop-out and on the motor load.

Static overload

When VSM units is overloaded (the current limit in parameter 221 has been reached), the controls will reduce the output frequency in an attempt to reduce the load.

If the overload is excessive, a current may occur that makes the VSM unit cut out after approx. 1.5 sec.

**■ Acoustic noise**

Below are the typical values measured at a distance of 1 m from the unit at full load:

	2 pole	4 pole
VSM 005		54 dB(A)
VSM 011		58 dB(A)
VSM 015		59 dB(A)
VSM 022		58 dB(A)
VSM 030		61 dB(A)
VSM 040	62 dB(A)	63 dB(A)
VSM 055	64 dB(A)	
VSM 075		61 dB(A)

**■ Balance**

The Variable speed W motor is balanced to class R according to ISO2373 (reduced balance). For critical applications especially at high speed (>4000 RPM) special balance (class S) might be required.

■ **Derating**

The Variable speed W is thermally protected in case limits are exceeded. At high temperatures the switching frequency will be gradually reduced down to 2 kHz and eventually the motor will trip.

■ **Derating for ambient temperature**

The ambient temperature ( $T_{AMB,MAX}$ ) is the maximum temperature allowed. The average ( $T_{AMB,AVG}$ ) measured over 24 hours must be at least 5°C lower.

If the VSM units is operated at temperatures above 40 °C, a derating of the continuous output current is necessary.

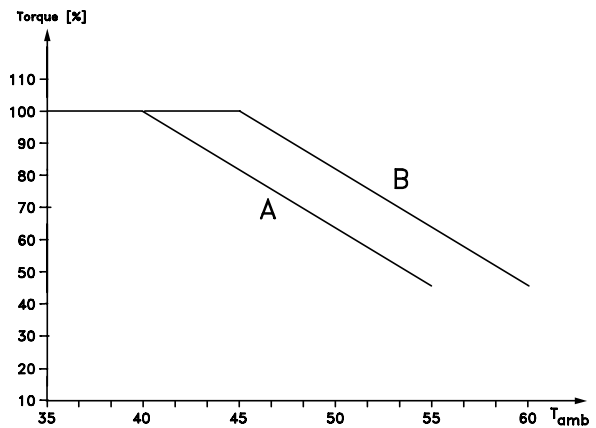

■ **Derating for air pressure**

Below 1000 m altitude no derating is necessary.

Above 1000 m the ambient temperature ( $T_{AMB}$ ) or max. output current ( $I_{VLT,MAX}$ ) must be derated in accordance with the following diagram:

- 1) Derating of output current versus altitude at  $T_{AMB} = \text{max. } 40^{\circ}\text{C}$
- 2) Derating of max.  $T_{AMB}$  versus altitude at 100% output current.

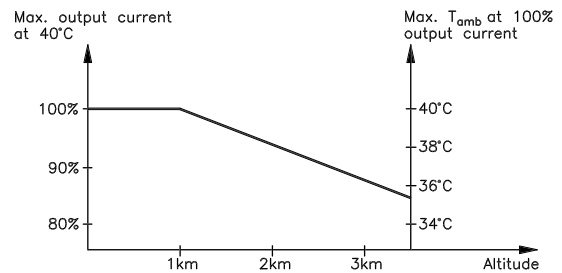

■ **Derating for running at low speed**

When a centrifugal pump or a fan is controlled by a VSM unit, it is not necessary to reduce the output at low speed because the load characteristic of the centrifugal pumps/fans, automatically ensures the necessary reduction.

VSM units running constant load torque applications continuously at low speed must be derated (see diagram) or an independent fan must be used (cooling option 6).

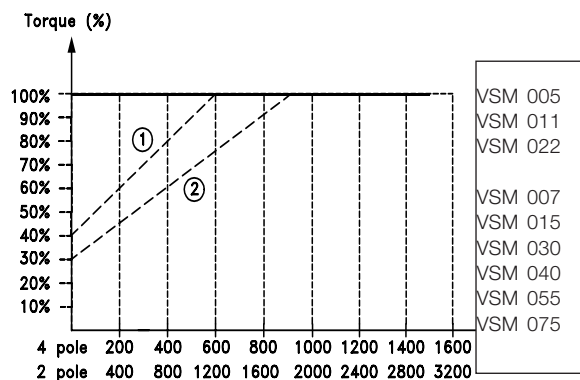

Nominal torque (100%) can be yielded up to 15 min and at a duty cycle up to 25% at low speed.

■ **Derating for high switching frequency**

The Variable speed W can use two different PWM schemes, SFAVM and 60° AVM. Factory setting is SFAVM. The PWM scheme can be changed in parameter 446. Below 25 Hz motor speed the VSM unit automatically change to SFAVM.

Factory setting of the switching frequency is 4000 Hz. It can be changed between 2 and 14 kHz in parameter 411.

A higher switching frequency leads to a quieter running unit but higher losses in the electronics of the VSM unit and makes an appropriate derating necessary.

■ **Vibration and shock**

The Variable speed W motor has been tested according to a procedure based on the following standards:

- IEC 68-2-6: Vibration (sinusoidal) - 1970
- IEC 68-2-34: Random vibration broad-band - general requirements
- IEC 68-2-35: Random vibration broad-band - high reproducibility
- IEC 68-2-36: Random vibration broad-band - medium reproducibility

The Variable speed W motor complies with requirements that correspond to conditions in the standards mentioned above.

■ **Air humidity**

The Variable speed W motor has been designed to meet the IEC 68-2-3 standard, EN 50178 item 9.4.2.2/DIN 40040, class E, at 40°C.

■ **Efficiency**

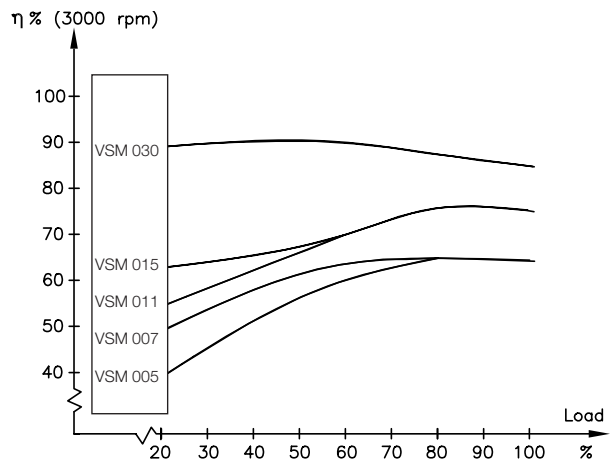

2 pole

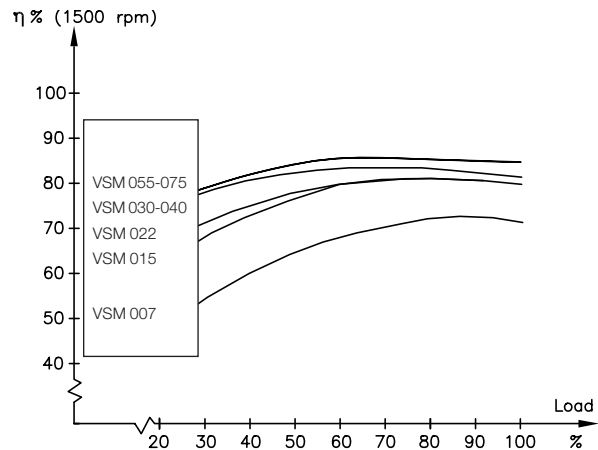

4 pole

■ **Mains supply interference/harmonics**

A VSM unit takes up a non-sinusoidal current from mains, which increases the input current  $I_{RMS}$ . A non-sinusoidal current can be transformed by means of a Fourier analysis and split up into sine wave currents with different frequencies, i.e. different harmonic currents  $I_N$  with 50 Hz as the basic frequency:

Harmonic currents	$I_1$	$I_5$	$I_7$	$I_{11}$
Hz	50 Hz	250 Hz	350 Hz	550 Hz
$I_n/I_1$ [%]	100%	44%	29%	8%

The harmonics do not affect the power consumption directly, but increase the heat losses in the installation (transformer, cables). Consequently, in plants with a rather high percentage of rectifier load, it is important to maintain harmonic currents at a low level to avoid overload of the transformer and high temperature in the cables.

Some of the harmonic currents might disturb communication equipment connected to the same transformer or cause resonance in connection with power-factor correction batteries.

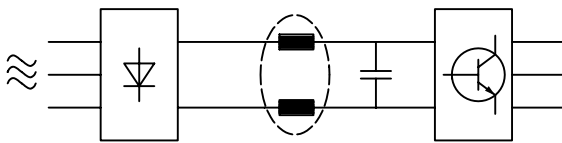

To ensure low, harmonic currents, a VSM unit has intermediate circuit coils as standard..

THD (current)  $\leq$  54%

The voltage distortion on the mains supply depends on the size of the harmonic currents multiplied by the mains impedance for the frequency in question.

The total voltage distortion THD is calculated on the basis of the individual voltage harmonics using the following formula:

$$THD = \frac{U_1}{\sqrt{U_2^2 + \dots + U_N^2}} \text{ (%)}$$

■ **Power factor**

The power factor is the relation between  $I_1$  and  $I_{RMS}$ .

The power factor for 3-phase control

$$= \frac{\sqrt{3} \times U \times I_1 \times \cos \varphi_1}{\sqrt{3} \times U \times I_{RMS}}$$

$$\text{Power factor} = \frac{I_1 \times \cos \varphi_1}{I_{RMS}} = \frac{I_1}{I_{RMS}} \approx 0.9 \text{ since } \cos \varphi = 1$$

The power factor indicates the extent to which the VSM unit imposes a load on the mains supply.

The lower the power factor, the higher the  $I_{RMS}$  for the same kW performance.

In addition, a high power factor indicates that the different harmonic currents are low.

$$I_{RMS} = \sqrt{I_1^2 + I_5^2 + I_7^2 + \dots + I_n^2}$$

■ **What is CE labelling?**

The purpose of CE labelling is to avoid technical obstacles to trade within EFTA and the EU. The EU has introduced the CE label as a simple way of showing whether a product complies with the relevant EU directives. The CE label says nothing about the specifications or quality of the product. Frequency converters are regulated by three EU directives:

■ **The machinery directive (89/392/EEC)**

All machines with critical moving parts are covered by the machinery directive, which came into force on 1 January 1995. Since a frequency converter is largely electrical, and the motor always will be placed in connection with other machines, it does not fall under the machinery directive. However, if a VSM unit is supplied for use in a machine, we provide information on safety aspects relating to the VSM unit. We do this by means of a manufacturer's declaration.

■ **The low-voltage directive (73/23/EEC)**

Frequency converters must be CE labelled in accordance with the low-voltage directive. The directive applies to all electrical equipment and appliances used in the voltage range of 50-1000 V AC and 75-1500 V DC.

**■ The EMC directive (89/336/EEC)**

EMC is short for electromagnetic compatibility. The presence of electromagnetic compatibility means that the mutual interference between different components/appliances is so small that the functioning of the appliances is not affected. The EMC directive came into force on 1 January 1996. The directive distinguishes between components, appliances, systems and installations.

**■ What is covered?**

The EU "Guidelines on the Application of Council Directive 89/336/EEC" outline three typical situations of using a VSM unit. For each of these situations, explanations are offered as to whether the situation in question is covered by the EMC directive and must be CE labelled.

1. The VSM unit is sold directly to the end-consumer. The VSM unit is for example sold to a DIY market. The end-consumer is a layman. He installs the VSM unit himself for use with a hobby machine, a kitchen appliance, etc. For such applications, the VSM unit must be CE labelled in accordance with the EMC directive.
2. The VSM unit is sold for installation in a plant. The plant is built up by professionals of the trade. It could be a production plant or a heating/ventilation plant designed and installed by professionals of the trade. Neither the VSM unit nor the finished plant has to be CE labelled under the EMC directive. However, the unit must comply with the basic EMC requirements of the directive. The installer can ensure this by using components, appliances and systems that are CE labelled under the EMC directive.
3. The FC motor is sold as part of a complete system. The system is being marketed as complete. It could be e.g. an air-conditioning system. The complete system must be CE labelled in accordance with the EMC directive. The manufacturer who supplies the system can ensure CE labelling under the EMC directive either by using CE labelled components or by testing the EMC of the system. If he chooses to use only CE labelled components, he does not have to test the entire system.

**■ Brook crompton Variable speed W motor and CE labelling**

CE labelling is a positive feature when used for its original purpose, i.e. to facilitate trade within the EU and EFTA.

However, CE labelling may cover many different specifications. This means that it has to be checked what a given CE label specifically covers.

The specifications covered can in fact be widely different. That is why a CE label can give the installer a false feeling of security when using a VSM unit as a component in a system or an appliance.

We CE label our Variable speed W motors in accordance with the low-voltage directive. This means that as long as the VSM unit is installed correctly, we guarantee that it complies with the low-voltage directive. We issue a declaration of conformity that confirms our CE labelling in accordance with the low-voltage directive.

The CE label also applies to the EMC directive, on condition that the instructions given in the Operating Instructions for EMC-correct installation and filtering have been followed. On this basis, a declaration of conformity in accordance with the EMC directive is issued.

The Quick Guide gives detailed instructions for installation to ensure that your installation is EMC-correct. Furthermore, we specify which norms that are complied with by our different products.

We offer the filters that can be seen from the specifications and gladly provide other types of assistance that can help you obtain the best EMC result.

**■ Compliance with EMC directive 89/336/EEC**

In the great majority of cases, the Variable speed W motor is used by professionals of the trade as a complex component forming part of a larger appliance, system or installation. It must be noted that the responsibility for the final EMC properties of the appliance, system or installation rests with the installer. As an aid to the installer, Brook crompton has prepared EMC installation guidelines for the Power Drive System. The standards and test levels stated for Power Drive Systems are complied with, provided the right EMC-correct instructions for installation have been followed, see electrical installation.

■ EMC standards



NOTE!

- All EMC specifications are stated with factory settings.
- Maximum 4 kHz switching frequency.
- Screened data/control cables must be used for surge protection.
- The VSM unit must be connected to earth in order to comply.
- Maximum/minimum line impedance  
 $Z_{max} = 0.24 + j0.15 \text{ ohm}$ ;  $Z_{min} = 0 + j0 \text{ ohm}$ .  
 (EN 61800-3 commutation notches)

Generic standards

The generic standards are stated in the EMC directive (89/336/EEC).

The VSM unit complies with:

*EN 50081-1<sup>1)</sup>, EN 50082-1.*

Residential, commercial and light industrial environment.

*EN 50081-2, EN 50082-2.*

Industrial environment.

<sup>1)</sup>Emission levels stated by EN 50081-1 are only fulfilled by VSM units with class B-1 optional filter.

Furthermore the VSM unit complies with:  
 DIN VDE 0160/1990 <sup>2)</sup>

<sup>2)</sup>'Protection against overvoltage 7.3.1. class1'

Product standards

The product standards are stated in EN 61800-3 (IEC 1800-3).

The VSM unit complies with:

*EN 61800-3, unrestricted distribution<sup>3)</sup>.*

*EN 61800-3, restricted distribution.*

<sup>3)</sup> Emission levels stated by EN 61800-3 unrestricted distribution are only fulfilled by VSM units with class B-1 filter.

Basic standards, emissions

- *EN 55011*: Limits and methods of measuring radio disturbance characteristics of industrial, scientific and medical (ISM) radio-frequency equipment.

- *EN 55022*: Limits and methods of measuring radio disturbance characteristics of information technology equipment.
- *EN 61000-3-2*: Limits for harmonic current emissions (equipment input current  $\leq 16 \text{ A}$ )
- *EN 61000-3-4*: Limits for harmonic current emissions (equipment input current  $\geq 16 \text{ A}$ )

Basic standards, immunity

- *EN 61000-2-4 (IEC 1000-2-4)*:  
 Compatibility levels  
 Simulation of voltage and frequency fluctuations, harmonics and commutation notches on the power line.
- *EN 61000-4-2 (IEC 1000-4-2)*:  
 Electrostatic discharge (ESD)  
 Simulation of electrostatic discharge.
- *EN 61000-4-4 (IEC 1000-4-4)*:  
 Fast transients, burst 5/ 50 nS  
 Simulation of transients caused by switching of contactors, relays or similar devices.
- *EN 61000-4-5 (IEC 1000-4-5)*:  
 Surges 1.2/ 50  $\mu\text{S}$ .  
 Simulation of transients caused by e.g. lightning that strikes near an installation.
- *EN 61000-4-6 (IEC 1000-4-6)*:  
 Radio-frequency electromagnetic field.  
 Amplitude modulated.  
 Simulation of interference caused by radio transmission equipment.
- *ENV 50140*:  
 Radio-frequency electromagnetic field. Pulse modulated.  
 Simulation of interference caused by GSM mobile phones.

General aspects of EMC emissions

For high frequency shielding, screened cables used for Profibus, standard bus, control cables and signal interface must in general be connected to the enclosure at both ends.

General aspects of EMC immunity

If there are problems with low frequency interference (ground loops), screened cable used for Profibus, standard bus, control cables and signal interface can be left open at one end.

■ **Aggressive environments**

In common with all electronic equipment, a frequency converter contains a large number of mechanical and electronic components, all of which are vulnerable to environmental effects to some extent.



The frequency converter should not therefore be installed in environments with airborne liquids, particles or gases capable of affecting and damaging the electronic components. Failure to take the necessary protective measures increases the risk of stoppages, thus reducing the life of the frequency converter.

Liquids can be carried through the air and condense in the frequency converter. In addition to this, liquids may cause corrosion of components and metal parts.

Steam, oil and salt water may cause corrosion of components and metal parts.

In such environments, equipment with enclosure rating  $\geq$  IP 54 is recommended.

In environments with high temperatures and humidity, corrosive gases such as sulphur, nitrogen and chlorine compounds will cause chemical processes on the frequency converter components. Such chemical reactions will rapidly affect and damage the electronic components.



**NOTE!**

Mounting frequency converters in aggressive environments will increase the risk of stoppages and furthermore considerably reduce the life of the converter.

Before the installation of the frequency converter, the ambient air should be checked for liquids, particles and gases. This may be done by observing existing installations in this environment. Typical indicators of harmful airborne liquids are water or oil on metal parts, or corrosion of metal parts.

Excessive dust particle levels are often found on installation cabinets and existing electrical installations.

One indicator of aggressive airborne gases is blackening of copper rails and cable ends on existing installations.



**Chapter 11**

- List of warnings and alarms ..... page 92
- What if the motor does not start? ..... page 92
- Warnings ..... page 93
- Warning words 1 + 2 and Alarm word ..... page 95

■ **List of warnings and alarms**

The table gives the different warnings and alarms and indicates whether the fault locks the VSM unit. After Trip locked, the mains supply must be cut and the fault must be corrected. Reconnect the mains supply and reset the VSM unit before being ready.

Wherever a cross is placed under both Warning and Alarm, this can mean that a warning precedes the alarm. It can also mean that it is possible to program whether a given fault is to result in a warning or an alarm. After a trip, alarm and warning will flash, but if the fault is removed, only alarm will flash. After a reset, the VSM unit will be ready to start operation again.

No.	Description	Warning	Trip Alarm	Trip locked
2	Live zero fault (LIVE ZERO ERROR)	X	X	
4	Phase loss (MAINS PHASE LOSS)	X	X	X
5	Voltage warning high (DC LINK VOLTAGE HIGH)	X		
6	Voltage warning low (DC LINK VOLTAGE LOW)	X		
7	Overvoltage (DC LINK OVERVOLT)		X	X
8	Undervoltage (DC LINK UNDERVOLT)		X	
9	Inverter overload (INVERTER TIME)	X	X	
11	Motor thermistor (MOTOR THERMISTOR)		X	
12	Current limit (CURRENT LIMIT)	X		
13	Overcurrent (OVERCURRENT)		X	X
14	Earth fault (EARTH FAULT)		X	X
15	Supply fault (SWITCH MODE FAULT)		X	X
16	Short-circuit (CURR.SHORT CIRCUIT)		X	X
17	Standard bus timeout (STD BUS TIMEOUT)	X	X	
18	HPFB bus timeout (HPFB TIMEOUT)	X	X	
33	Out of frequency range (OUT FREQ RNG/ROT LIM)	X		
34	HPFB error (HPFB ALARM)	X	X	
35	Inrush fault (INRUSH FAULT)		X	X
36	Overtemperature (OVERTEMPERATURE)	X	X	
37	Internal error (INTERNAL ERROR)		X	X

■ **What if the motor does not start?**

- Make sure no parameters have been changed from initial delivery status (factory setting). Use the Local Control Panel or serial port to reset to factory setting.
- Make sure no STOP command have been issued by the optional control panel keyboard (local stop) Control Panel STOP can only be restarted by the Control Panel START button.
- Check the Light Emitting Diodes visible through a hole in the inside isolation cover (see drawing on page 16), follow table below.



Warning:  
Extreme care must be taken when operating the unit with open lid.

Green LED 302	Yellow LED 301	Red LED 300	Action
OFF	OFF	OFF	Apply power
ON	OFF	OFF	Apply <b>start and reference</b> signals , (see drawing on page 16)
ON	OFF	ON	Apply and remove <b>reset</b> signal according to the drawing on page 16.
ON	ON	ON	Switch off power until all LED's have turned off

For further information see the quick setup MG.98.Hx.xx.

■ **Warnings**

The display flashes between normal state and warning. A warning comes up on the first and second line of the display. See examples below:

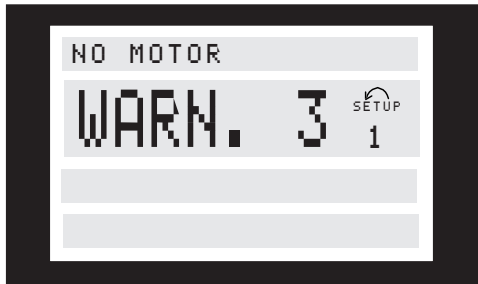

**Alarm messages**

The alarm comes up in the 2. and 3. line of the display, see example below:



**WARNING/ALARM 2**

**Live zero fault (LIVE ZERO ERROR):**

The current signal on terminal 1 is less than 50% of the value set in parameter 336 *Terminal 1, min. scaling*.

**WARNING/ALARM 4**

**Phase loss (MAINS PHASE LOSS):**

Phase missing on the supply side.  
Check the supply voltage to the VSM unit.

**WARNING 5**

**Voltage warning high**

**(DC LINK VOLTAGE HIGH):**

The intermediate circuit voltage (DC) is higher than the overvoltage limit of the control system, see table on this page. The VSM unit is still active.

**WARNING 6**

**Voltage warning low (DC LINK VOLTAGE LOW):**

The intermediate circuit voltage (DC) is below the undervoltage limit of the control system, see table below. The VSM unit is still active.

**ALARM 7**

**Overvoltage (DC LINK OVERVOLT):**

If the intermediate circuit voltage (DC) exceeds the inverter overvoltage limit (see table), the VSM unit will trip. Furthermore, the voltage will be stated in the display.

**ALARM 8**

**Undervoltage (DC LINK UNDERVOLT):**

If the intermediate circuit voltage (DC) drops below the inverter lower voltage limit (see table on this page), the VSM unit will trip after 3 - 28 sec., depending on unit. Furthermore, the voltage will be stated in the display. Check whether the supply voltage matches the VSM unit, see technical data.

**WARNING/ALARM 9**

**Inverter overload (INVERTER TIME):**

The electronic, thermal inverter protection reports that the VSM unit is about to cut out because of an overload (too high current for too long). The counter for electronic, thermal inverter protection gives a warning at 95% and trips at 100%, while giving an alarm. The VSM unit cannot be reset until the counter is below 90%.

Trip/Alarm/warning limits:

Variable speed W motor	3 x 380 - 480 V
	[VDC]
Undervoltage	410
Voltage warning low	440
Voltage warning high	760
Overvoltage	760*

\* 760V in 5 sec. or 800V immediately.

The voltages stated are the intermediate circuit voltage of the VSM unit.

**Warnings and alarms, cont.**
**ALARM 11**
**Motor thermistor (MOTOR THERMISTOR):**

If a thermistor is mounted and parameter 128 is set to *Enable* [1], the VSM unit will trip if the motor gets too hot.

**WARNING 12**
**Current limit (CURRENT LIMIT):**

The current is higher than the value in parameter 221 (in motor operation).

**ALARM 13**
**Overcurrent (OVERCURRENT):**

The inverter peak current limit (approx. 230% of the rated current) has been exceeded. The VSM unit will trip, while giving an alarm.

Turn off the VSM unit and check whether the motor shaft can be turned.

**ALARM: 14**
**Earth fault (EARTH FAULT):**

There is a discharge from the output phases to earth, either between the inverter and the motor or in the motor itself.

**ALARM: 15**
**Supply fault (SWITCH MODE FAULT):**

Fault in the switch mode power supply (internal 24 V supply).

Contact Brook crompton.

**ALARM: 16**
**Short-circuiting (CURR.SHORT CIRCUIT):**

There is short-circuiting on the motor terminals or in the motor itself.

Contact Brook crompton.

**NB!**

If shock loads occur this alarm may appear.

**WARNING/ALARM 17**
**Standard bus timeout (STD BUSTIMEOUT)**

There is no communication to the VSM unit.

The warning will only be active when parameter 514 has been set to another value than *OFF*.

If parameter 514 has been set to *stop and trip*, it will first give a warning and then ramp down until it trips, while giving an alarm.

Parameter 513 *Bus time interval* could possibly be increased.

**WARNING/ALARM 18**
**HPFB bus timeout (HPFB BUS TIMEOUT)**

There is no communication with the VSM unit.

The warning will only be active when parameter 804 has been set to another value than *OFF*.

If parameter 804 has been set to *Stop and trip*, it will first give a warning and then ramp down until it trips, while giving an alarm.

Parameter 803 *Bus time out* could possibly be increased.

**WARNING 33**
**Out of frequency range:**

This warning is active if the output frequency has reached parameter 201 *Output frequency low limit* or parameter 202 *Output frequency high limit*.

**WARNING/ALARM 34**
**HPFB error (HPFB ALARM):**

The profibus communication is not working correctly.

**ALARM 35**
**Inrush fault (INRUSH FAULT):**

This warning occurs when the unit has been switched on too many times within 1 minute.

**WARNING/ALARM 36**
**Overtemperature (OVERTEMPERATURE):**

A warning occurs at 78°C and the VSM unit trips at 90°C. The unit can be reset when the temperature is below 70°C.

**ALARM: 37**
**Internal error (INTERNAL ERROR):**

An error has occurred in the system. Contact Brook crompton.

**■ Warning words 1 + 2 and Alarm word**

Warning words 1 + 2 and alarm word are shown on the display in Hex format. If there are more than one warning or alarm, a sum of all warnings or alarms will be shown.

Warning words 1 + 2 and alarm word can also be displayed using the serial bus in parameter 540, 541 and 538.

Bit (Hex)	Warning word 1
00000008	HPFB timeout
00000010	Standard bus timeout
00000040	Current limit
00000200	Inverter overload
00001000	Voltage warning low
00002000	Voltage warning high
00004000	Phase loss
00010000	Live zero error warning
00400000	Output freq. limit warning
00800000	HPFB error
40000000	24 V supply warning
80000000	Inverter temp. high

Bit (Hex)	Warning word 2
01	Ramping
04	Start clockwise/counterclockwise
08	Slow down
10	Catch-up
8000	Frequency limit

Bit (Hex)	Alarm word
00000002	Trip lock
00000040	HPFB timeout
00000080	Standard bus timeout
00000100	Short circuit
00000200	24 V supply fault
00000400	Earth fault
00000800	Overcurrent
00004000	Motor thermistor
00008000	Inverter overload
00010000	Undervoltage
00020000	Overvoltage
00040000	Phase loss
00080000	Live zero error
00100000	Overtemperature
02000000	HPFB error
08000000	Inrush fault
10000000	Internal error



Chapter 12

■ List of Parameters ..... page 98

**List of Parameters**

Functions to programme, to control, and to monitor via bus (PROFIBUS) or by PC.

	Function	Range/number of settings/value	Factory setting	Parameter No.	
<b>Operation and display</b>	Language	6	English	Parameter 001	
	Local/remote control	2	Remote control	Parameter 002	
	Local reference		000.000	Parameter 003	
	Active Setup	4	Setup 1	Parameter 004	
	Programming Setup	4	Active setup	Parameter 005	
	Copying of Setups	4	No copying	Parameter 006	
	LCP copy	4	No copying	Parameter 007	
	Display scaling of motor frequency		100	Parameter 008	
	Display line 2	24	Frequency [Hz]	Parameter 009	
	Display line 1.1		Reference [%]	Parameter 010	
	Display line 1.2		Motor current [A]	Parameter 011	
	Display line 1.3		Power [kW]	Parameter 012	
	Local control/configuration	5	LCP digital control/par. 100	Parameter 013	
	Local stop	2	Possible	Parameter 014	
	Local jog	2	Not possible	Parameter 015	
	Local reversing	2	Not possible	Parameter 016	
	Local reset of trip	2	Possible	Parameter 017	
	Lock for data change	2	Not locked	Parameter 018	
	<b>Load and motor</b>	Operating state at power up, local c.	3	Forced stop, use saved ref.	Parameter 019
Configuration		2	Speed, open loop mode	Parameter 100	
Torque characteristics		4	Constant torque	Parameter 101	
Motor power		XX.XX kW - dep. on unit		Parameter 102	
Motor voltage		XX.XX V - dep. on unit		Parameter 103	
Motor frequency		XX.X Hz - dep. on unit		Parameter 104	
Motor current		XX.XX A - dep. on unit		Parameter 105	
Rated motor speed		XX rpm - dep. on unit		Parameter 106	
DC braking time		0.0 (off) - 60.0 sec.	10.0 sec.	Parameter 126	
DC brake cut-in frequency		0.0 Hz - $f_{MAX}$	0.0 Hz	Parameter 127	
Motor thermal protection		2	Disable	Parameter 128	
DC braking voltage		0 - 100 %	0 %	Parameter 132	
Start voltage		0.00 - 100.00 V	Motor dependent	Parameter 133	
Start compensation		0.0 - 300.0 %	100.0 %	Parameter 134	
U/f ratio		0.00 - 20.00 V/Hz	Motor dependent	Parameter 135	
Slip compensation		-500.0 - +500.0 %	100.0 %	Parameter 136	
DC holding voltage		0 - 100 %	0 %	Parameter 137	
Brake cut out frequency		0.5 - 132 Hz	3.0 Hz	Parameter 138	
Brake cut in frequency		0.5 - 132 Hz	3.0 Hz	Parameter 139	
<b>References and limits</b>		Rotation direction	3	Only clockwise 0 - 132 Hz	Parameter 200
		Min. output frequency ( $f_{MIN}$ )	0.0 Hz - $f_{MAX}$	0.0 Hz	Parameter 201
	Max. output frequency ( $f_{MAX}$ )	$f_{MIN}$ - $f_{RANGE}$	$f_{RANGE}$ (132 Hz)	Parameter 202	
	Reference/feedback range	Min. - max./-max.- +max.	Min. - Max.	Parameter 203	
	Minimum reference	-100,000.000 - $Ref_{MAX}$	0.000	Parameter 204	
	Maximum reference	$Ref_{MIN}$ - 100,000.000	50.000	Parameter 205	
	Ramp-up time 1	0.05 - 3600.00 sec.	3.00 sec.	Parameter 207	
	Ramp-down time 1	0.05 - 3600.00 sec.	3.00 sec.	Parameter 208	
	Jog ramp time	0.05 - 3600.00 sec.	3.00 sec.	Parameter 211	
	Quick stop ramp-down time	0.05 - 3600.00 sec.	3.00 sec.	Parameter 212	
Jog frequency	0 Hz - $f_{MAX}$	10.0 Hz	Parameter 213		
Reference function	2	Sum	Parameter 214		

## VSM

	Function	Range/number of settings	Factory setting	Parameter No.
	Preset reference 1	-100.00 % - +100.00 %	0.00 %	Parameter 215
	Preset reference 2	-100.00 % - +100.00 %	0.00 %	Parameter 216
	Catch up/slow down value	0.00 - 100.00 %	0.00 %	Parameter 219
	Current limit for motor mode	Min.- max. limit in % of I <sub>RATED</sub>	Max. limit	Parameter 221
	Frequency bypass, bandwidth	0 (off) - 100 %	0 %	Parameter 229
	Frequency bypass 1	0.0 - 132 Hz	0.0 Hz	Parameter 230
	Frequency bypass 2	0.0 - 132 Hz	0.0 Hz	Parameter 231
	Time out	1 -99 sec.	10 sec.	Parameter 317
	Function after time out	Off/Stop and trip	Off	Parameter 318
	Pulse reference/feedback, max. freq.	100 - 70000 Hz	5000 Hz	Parameter 327
<b>Inputs and Outputs</b>	Terminal 1, analog input current	3	No operation	Parameter 331
	Terminal 2, digital input	25	Reference	Parameter 332
	Terminal 3, digital input	25	Reset	Parameter 333
	Terminal 4, digital input	24	Start	Parameter 334
	Terminal 5, digital input	23	Jog	Parameter 335
	Terminal 1, min. scaling	0.0 - 20.0 mA	0.0 mA	Parameter 336
	Terminal 1, max. scaling	0.0 - 20.0 mA	20.0 mA	Parameter 337
	Terminal 2, min. scaling	0.0 - 10.0 V	0.0 V	Parameter 338
	Terminal 2, max. scaling	0.0 - 10.0 V	10.0 V	Parameter 339
		Output functions	21	No operation
	Brake function	Off/AC braking	Off	Parameter 400
	Reset function	11	Manual reset	Parameter 405
	Switching frequency	1.5 - 14.0 kHz	Unit dependent	Parameter 411
	Variable switching frequency	3	Temp. dep. sw. freq.	Parameter 412
	Overmodulation function	Off/On	On	Parameter 413
<b>Special functions</b>	Minimum feedback	-100000 - FB <sub>HIGH</sub>	0	Parameter 414
	Maximum feedback	FB <sub>LOW</sub> - 100,000	1500	Parameter 415
	Reference/feedback unit	42	%	Parameter 416
	Process PID normal/inverse ctrl.	Normal/inverse	Normal	Parameter 437
	Process PID anti windup	Disable/Enable	Enable	Parameter 438
	Process PID start frequency	f <sub>MIN</sub> - f <sub>MAX</sub>	f <sub>MIN</sub>	Parameter 439
	Process PID proportional gain	0.00 (off) - 10.00	0.01	Parameter 440
	Process PID integral time	0.01 - 9999 sec. (off)	9999 sec.	Parameter 441
	Process PID differentiation time	0.00 (off) - 10.00 sec.	0.00 sec.	Parameter 442
	Process PID different. gain limit	5 -50	5	Parameter 443
Process PID lowpass filter time	0.1 - 10.00 sec.	0.1 sec.	Parameter 444	
	Flying start	4	Disable	Parameter 445
	Switching pattern	2	SFAVM	Parameter 446
<b>Serial communication</b>	Bus address	1 - 126	1	Parameter 500
	Baudrate	300 - 9600 Baud/6	9600 Baud	Parameter 501
	Coasting	4	Logic or	Parameter 502
	Quick-stop	4	Logic or	Parameter 503
	DC-brake	4	Logic or	Parameter 504
	Start	4	Logic or	Parameter 505
	Reversing	4	Logic or	Parameter 506
	Selection of setup	4	Logic or	Parameter 507
	Selection of speed	4	Logic or	Parameter 508
	Bus jog 1	0.0 - f <sub>MAX</sub>	10.0 Hz	Parameter 509
	Bus jog 2	0.0 - f <sub>MAX</sub>	10.0 Hz	Parameter 510
	Telegram profile	Profidrive/VSM drive	VSM Drive	Parameter 512
	Bus time interval		1 sec.	Parameter 513
	Bus time interval function	6	Off	Parameter 514

Function	Range/number of settings	Factory setting	Parameter No.
Data read-out: Reference	XXX.X		Parameter 515
Data read-out: Refer. unit	Hz/rpm		Parameter 516
Data read-out: Feedback			Parameter 517
Data read-out: Frequency	Hz		Parameter 518
Data read-out: Frequency x scale	Hz		Parameter 519
Data read-out: Current	A x 100		Parameter 520
Data read-out: Torque	%		Parameter 521
Data read-out: Power	kW		Parameter 522
Data read-out: Power	hp		Parameter 523
Data read-out: Motor voltage	V		Parameter 524
Data read-out: DC link voltage	V		Parameter 525
Data read-out: FC therm.	0 - 100 %		Parameter 527
Data read-out: Digital input			Parameter 528
Data read-out: External reference	-200.0 - +200.0 %		Parameter 533
Data read-out: Status word, binary			Parameter 534
Data read-out: FC temperature	°C		Parameter 537
Data read-out: Alarm word, binary			Parameter 538
Data read-out: Control word, binary			Parameter 539
Data read-out: Warning word, 1			Parameter 540
Data read-out: Warning word, 2			Parameter 541
Data read-out: Terminal 1, analog input	mA X 10		Parameter 542
Data read-out: Terminal 2, analog input	V X 10		Parameter 543
Operating data: Operating hours	0 - 130,000.0 hours		Parameter 600
Operating data: Hours run	0 - 130,000.0 hours		Parameter 601
Operating data: Number of power-up's	0 - 9999		Parameter 603
Operating data: Number of overtemp.	0 - 9999		Parameter 604
Operating data: Number of overvoltages	0 - 9999		Parameter 605
Fault log, read-out: Error code	Index XX - XXX		Parameter 615
Fault log, read-out: Time	Index XX - XXX		Parameter 616
Fault log, read-out: Value	Index XX - XXX		Parameter 617
Reset of hours-run counter	No reset/reset	No reset	Parameter 619
Operation mode	3	Normal function	Parameter 620
Nameplate: FC motor type	Depends on unit		Parameter 621
Nameplate: Software version no.	Depends on unit		Parameter 624
LCP version	Depends on unit		Parameter 625
Nameplate: Database identification no.	Depends on unit		Parameter 626
Nameplate: Application option type			Parameter 628
Nameplate: Communication option type			Parameter 630
BMC software identification			Parameter 632
Motor database identification			Parameter 633
Unit identification for communication			Parameter 634
Software part No.			Parameter 635

**Technical functions**

**Chapter 13**

■ Index .....page 102

**Index**

**A**

Acoustic noise ..... 83  
 Aggressive environments ..... 89  
 Air humidity ..... 85  
 Alarm word ..... 95  
 Alarms ..... 92  
 Alignment ..... 22  
 Axial and radial loads ..... 22, 23

**B**

Bearings ..... 19  
 Bolt torques ..... 23, 24

**C**

CE labelling ..... 86  
 Cleaning of the VSM unit ..... 23  
 Compliance with EMC directive 89/336/EEC ..... 87  
 Control keys ..... 27  
 Control panel ..... 26

**D**

Databytes ..... 74  
 Parameter bytes ..... 74  
 Process-bytes ..... 76  
 Derating for air pressure ..... 84  
 Derating for ambient temperature ..... 84  
 Derating for high switching frequency ..... 85  
 Derating for running at low speed ..... 84  
 Design Guide ..... 6  
 Dimensions ..... 20  
 Face mounting - B14, B34 (B3+B14) ..... 21  
 Flange mounting - B5, B35 (B3+B5) ..... 21  
 Foot mounting - B3 ..... 20  
 Display ..... 26  
 Display line 2 ..... 38  
 Display mode ..... 28

**E**

Earth fault ..... 94  
 Earth leakage current ..... 82  
 Efficiency ..... 85  
 EMC directive ..... 87  
 EMC standards ..... 88  
 Extreme running conditions ..... 83  
 Mains drop-out ..... 83  
 Motor-generated overvoltage ..... 83  
 Static overload ..... 83

**F**

Forced ventilation units ..... 24

**G**

Galvanic isolation (PELV) ..... 82

**H**

Handling the VSM unit ..... 19, 20

**I**

Inertia ..... 19  
 Initialisation ..... 69  
 Installation of the VSM unit ..... 22  
 Integration of frequency converter and motor ..... 8  
 Control structures ..... 8  
 Key diagram for Variable speed W motors ..... 8

**L**

LEDs ..... 26  
 LED 300-304 ..... 16  
 Local control panel ..... 25  
 Changing data ..... 30  
 Control keys ..... 27  
 Control panel ..... 26  
 Display mode ..... 28  
 Display read-out state ..... 28  
 LCD-display ..... 26  
 LED ..... 26  
 Menu mode ..... 30  
 Menu structure ..... 32  
 Parameter selection ..... 29  
 Local Operation Pad ..... 34  
 Local reference ..... 36  
 Low-voltage directive (73/23/EEC) ..... 86

**M**

Machinery directive ..... 86  
 Mains supply interference/harmonics ..... 86

**O**

Ordering ..... 10  
 Ordering form ..... 12  
 Output shafts ..... 19

**P**

Parameters ..... 35  
 Active Setup ..... 37  
 Address ..... 61  
 Baudrate ..... 61  
 BMC software identification ..... 70  
 Bus jog 1 ..... 62  
 Bus jog 2 ..... 62  
 Bus time interval ..... 62  
 Bus time interval function ..... 63  
 Catch up/slow down value ..... 48  
 Coasting ..... 61  
 Configuration ..... 42  
 Copying of Setups ..... 37  
 Current limit for motor mode ..... 49  
 Data read-out: Alarm word ..... 66  
 Data read-out: Control word ..... 66  
 Data read-out: Current ..... 64  
 Data read-out: DC link voltage ..... 65  
 Data read-out: Digital input ..... 65  
 Data read-out: External reference % ..... 65  
 Data read-out: FC therm. .... 65

Data read-out: Feedback .....	63	Operating data: Number of overtemperatures ..	68
Data read-out: Frequency .....	63	Operating data: Number of overvoltages .....	68
Data read-out: Inv. temperature .....	66	Operating data: Number of power-up's .....	67
Data read-out: Motor voltage .....	64	Operating data: Operating hours .....	67
Data read-out: Power, HP .....	64	Operating mode (OPERATION MODE) .....	69
Data read-out: Power, kW .....	64	Operating state at power up, local control .....	41
Data read-out: Reference % .....	63	Overmodulation function .....	57
Data read-out: Reference unit .....	63	Parameter number (PNU) .....	75
Data read-out: Status word, binary .....	65	Preset reference 1 .....	48
Data read-out: Terminal 1, analogue input .....	67	Preset reference 2 .....	48
Data read-out: Terminal 2, analogue input .....	67	Process PID anti windup .....	58
Data read-out: Torque .....	64	Process PID diff. gain limit .....	59
Data read-out: Warning word, 1 .....	66	Process PID differentiation time .....	59
Data read-out: Warning word, 2 .....	66	Process PID integral time .....	59
DC brake cut-in frequency .....	43	Process PID lowpass filter time .....	60
DC braking time .....	43	Process PID Normal/inverse control .....	58
DC braking voltage .....	43	Process PID proportional gain .....	59
DC-brake .....	61	Process PID start frequency .....	58
Display line 1.1 .....	39	Programming Setup .....	37
Display line 1.2 .....	39	Quick stop ramp-down time .....	47
Display line 1.3 .....	39	Quick-stop .....	61
Display line 2 .....	38	Ramp-down time 1 .....	47
Display scaling of motor frequency .....	38	Ramp-up time 1 .....	47
Fault log: Error code .....	68	Rated motor speed .....	43
Fault log: Time .....	68	Reference function .....	48
Fault log: Value .....	69	Reference/feedback range .....	46
Flying start .....	60	Reset function .....	56
Frequency bypass 1 .....	49	Reset of hours-run counter .....	69
Frequency bypass, bandwidth .....	49	Reversing .....	61
Function after time out .....	50	Rotation direction .....	45
Jog frequency .....	48	Selection of Setup .....	61
Jog ramp time .....	47	Selection of speed .....	61
Language .....	36	Slip compensation .....	44
LCP copy .....	38	Start .....	61
Local Control/Configuration .....	40	Start compensation .....	44, 45
Local jog .....	41	Start voltage .....	43
Local reference .....	36	Switching frequency .....	56
Local reset of trip .....	41	Switching pattern .....	60
Local reversing .....	41	Telegram profile .....	62
Local stop .....	40	Terminal 1, analogue input current .....	50
Local/remote control .....	36	Terminal 1, max. scaling .....	53
Lock for data change .....	41	Terminal 2, analogue/digital input .....	51
Max. output frequency .....	46	Terminal 2, max. scaling .....	54
Maximum feedback .....	57	Terminal 2, min. scaling .....	53
Maximum reference .....	46	Terminal 3, digital input .....	51
Min. output frequency .....	45	Terminal 4, digital input .....	51
Minimum feedback .....	57	Terminal 5, digital input .....	51
Minimum reference .....	46	Terminal 9, output functions .....	54
Motor current .....	42	Time out .....	50
Motor database identification .....	70	Torque characteristics .....	42
Motor frequency .....	42	U/f ratio .....	44
Motor power .....	42	Unit identification for communication .....	70
Motor voltage .....	42	Variable switching frequency .....	56
Nameplate: Application option type .....	70	PC software for serial communication .....	72
Nameplate: Communication option type .....	70	Periodic maintenance of motor part .....	23
Nameplate: Database identification no. ....	70	Plug kit .....	33
Nameplate: FC type .....	69	Power factor .....	86
Nameplate: Software version no. ....	69	Process-bytes .....	76
Operating data: Hours run .....	67		

Product concept .....	7
Product range .....	10
Inverter versions .....	10
Mounting versions .....	10

## Q

Quick Guide .....	6
Quick menu .....	29

## R

RCD .....	82
Remote mounting kit.....	33

## S

Safety .....	24
Safety regulations .....	4
Serial bus .....	73
Service plug kit .....	33
Start .....	61

## T

Technical data .....	14, 16
Control card, analogue inputs: .....	15
Control card, digital/pulse and analogue outputs ..	15
Control card, digital/pulse inputs .....	14
Control card, pulse input: .....	14
Control card, RS 485 serial communication .....	15
Control characteristics .....	15
Externals .....	15
FCM 305-375 for 3 phase, 380-480 V .....	14
Mains supply .....	14
Torque characteristics .....	14
Telegram build-up .....	73
Data control byte (BCC) .....	74
Telegram length (LGE) .....	73
VLT address (ADR) .....	74
Telegram communication .....	73
Broadcast .....	73
Control and reply telegrams .....	73
Terminal arrangement .....	16

## V

Vibration and shock .....	85
---------------------------	----

## W

Warning against unintended start .....	4
Warning words .....	95
Warnings .....	92
warnings .....	92